



Service Contract to DG Enterprise

**Sustainable Industrial Policy –  
Building on the Ecodesign Directive –  
Energy-Using Product Group Analysis/2**

## **Lot 6: Air-conditioning and ventilation systems**

Contract No. ENTR / 2009/ 035/ LOT6/ SI2.549494

### **Draft Report Task 5**

#### **Technical Analysis Ventilation Systems**

**for non residential and collective residential applications,**

**BAT and BNAT**

*Prepared by VHK*

*Version of 2 May 2011*

Main contractor: ARMINES, France

Project leader: Philippe RIVIERE

#### **PARTICIPANTS**

Jérôme ADNOT, Olivier GRESLOU, Philippe RIVIERE, Joseph SPADARO  
**ARMINES, France**

René KEMNA, Rob VAN HOLSTEIJN, Martijn VAN ELBURG, William LI, Roy van den BOORN  
**VHK, The Netherlands**

Roger HITCHIN, Christine POUT  
**BRE, UK**

#### **Legal disclaimer**

The sole responsibility for the content of this report lies with the authors. It does not necessarily represent the opinion of the European Community. The European Commission is not responsible for any use that may be made of the information contained therein.

Notice:

This report has been prepared by the authors to the best of their ability and knowledge. The authors do not assume liability for any damage, material or immaterial, that may arise from the use of the report or the information contained therein.

## Contents

<b>1.</b>	<b>Introduction</b>	<b>5</b>
<b>2.</b>	<b>Fan Systems</b>	<b>6</b>
<b>2.1</b>	<b>Introduction</b>	<b>6</b>
<b>2.2</b>	<b>Fans</b>	<b>7</b>
2.2.1	Fan types	7
2.2.2	Other strict fan efficiency factors	11
2.2.3	Fan size and efficiency	11
2.2.4	Sizing for optimum performance and efficiency	11
2.2.5	Part load system efficiency	18
2.2.6	Efficiency rating	19
<b>2.3</b>	<b>Motors and Motor efficiency</b>	<b>25</b>
2.3.1	Motor types	25
2.3.2	Factors affecting motor efficiency	26
2.3.3	Sizing and part load performance	27
2.3.4	Motor performance rating	29
2.3.5	Power transmission (drives)	30
<b>3.</b>	<b>Fan in- and outlet, filters</b>	<b>31</b>
<b>3.1</b>	<b>Total system pressure drop – Rules of thumb</b>	<b>31</b>
<b>3.2</b>	<b>Fan inlet and outlet – Aerodynamic inefficiencies</b>	<b>33</b>
3.2.1	General	33
3.2.2	Recommendations for fan inlets	33
3.2.3	Recommendations for fan outlets	34
<b>3.3</b>	<b>Filters</b>	<b>37</b>
3.3.1	Filter types and their aerodynamic properties	37
3.3.2	Filter types	37
3.3.3	Filter effectiveness	38
3.3.4	Filter efficiency	39
3.3.5	Electrostatic filter testing	41
3.3.6	Filter bypass leakage and other requirements	44
<b>4.</b>	<b>Heat Recovery</b>	<b>46</b>
<b>4.1</b>	<b>Introduction and definition</b>	<b>46</b>
<b>4.2</b>	<b>Categories</b>	<b>46</b>
<b>4.3</b>	<b>Efficiency</b>	<b>48</b>
<b>4.4</b>	<b>Applicable standards</b>	<b>49</b>
4.4.1	Stand-alone devices	49

4.4.2	Integrated in non-residential ventilation units	49
4.4.3	Integrated in residential ventilation units	51
<b>5.</b>	<b>Controls</b>	<b>52</b>
5.1	Introduction	52
5.2	Controls for central exhaust ventilation units (CEXH)	54
5.3	Controls for central heat recovery ventilation units (CHRV)	56
5.4	Controls for air handling units (AHUs)	56
<b>6.</b>	<b>Summary BAT and BNAT</b>	<b>57</b>
6.1	BAT	57
6.2	BNAT	58
	<b>List of Tables</b>	<b>59</b>
	<b>List of figures</b>	<b>60</b>
	<b>References</b>	<b>62</b>

## 1. Introduction

This is the draft report for Task 5 on the Ventilation Systems, as part of the preparatory study on Air Conditioning and Ventilation Systems in the context of the Ecodesign Directive: '**ENTR Lot 6 – Air Conditioning and Ventilation Systems**'.

This study is being carried out for the European Commission (DG ENTR). The consortium responsible for the study is Armines (lead contractor), BRE and VHK. Subcontractor for the underlying report is VHK.

Task 5 entails subtask 5.1 on the assessment of Best Available Technology (BAT) and subtask 5.2 regarding the Best Not (yet) Available Technology (BNAT). Especially for the non-residential ventilation systems these two are very much linked and will be discussed together. After the introductory chapter (Ch. 1), the underlying report is thus centered around the main components of the ventilation units:

- fan system (Ch. 2),
- fan in and outlets, filters (Ch. 3),
- heat recovery (Ch. 4) and
- controls (Ch.5).

Each of these chapters describes the main typology, design and performance considerations and energy efficiency characteristics. In the final chapter 6, BAT and BNAT technology are indicated.

## 2. Fan Systems

### 2.1 Introduction

A fan system is the combination of fan, motor and drive.

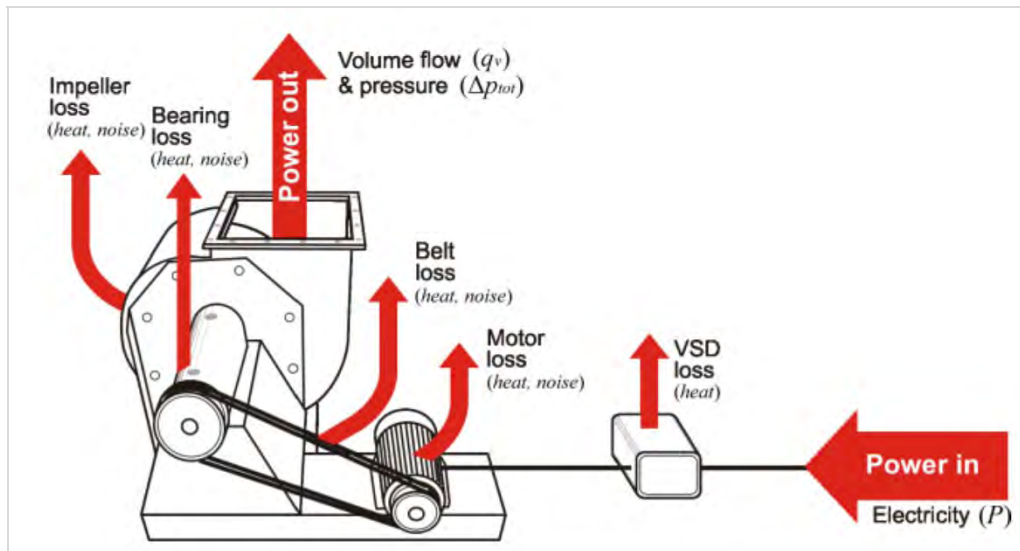

**Figure 5- 1: Losses from a traditional belt-driven centrifugal fan** [source: FMA]

The aim of this chapter is to identify design options for the ventilation products in the scope of this study (with individual fans >125 W) and set a reference for Best Available Technology. Furthermore, the chapter aims to provide some guidance for suitable parameters to set specific Ecodesign requirements.

Parameters to express fan efficiency and power consumption have been discussed in the Task 1 report, citing current EN ventilation standards and legislation. In the Task 2 report on the market and economic analysis, calculations were made with baseline values for fan system power to calculate electricity costs of units sold and installed in the EU-27. The Task 3 report describes fan applications and—in particular in Chapter 10—the loads

In parts, fan system efficiency and performance have been subject to preparatory studies for

- industrial fans (DG TREN Lot 11), culminating in a recently approved proposal for Ecodesign measures;
- industrial motors (DG TREN Lot 11), leading to Commission Regulation (EC).../640../2009;
- domestic ventilation units (DG TREN Lot 10), where currently (Nov. 2010) the Commission services are working on proposals for legislation.

These studies are an important source for the underlying study, as the Commission services are striving for consistency and minimal administrative and testing effort for stakeholders and Member States.

Fan system efficiency is a subject where there is a myriad of quality publications to draw from. In this chapter the authors have frequently used the most recent assessments, amongst others from AIVC<sup>1</sup> and the air handlers' manufacturer's association Eurovent<sup>2</sup> and the University of Trier<sup>3</sup>.

In the following paragraphs a summary is given of the efficiency and performance parameters that are in use for fan systems, i.e.

- the most comprehensive: fan system efficiency ;
- the most popular: Specific Fan Power (SFP) in  $W/(m^3/s)$ ;
- the most likely to be used for ('domestic') ventilation units with individual fans <125 W electric power input: Specific Power Input (SPI) in  $W/(m^3/h)$ ;
- the one used for Ecodesign measures industrial fans: FMEG

For each of these parameters, apart from a recap of the theoretical background, design options are discussed and the average and best available product values are given.

## 2.2 Fans

### 2.2.1 Fan types

There are three main types of fans: *centrifugal*, *axial*, and *mixed-flow*. A fourth type, *cross-flow* (or *tangential*) fans will not be mentioned further, due to their very low efficiency.

*Centrifugal* fans have impeller blades that are arranged like a cylindrical cage (Figure 5-2). The blades can be curved forwards (F-wheel), backwards (B-wheel), or straight radial (T-wheel); see Figure 5-3.

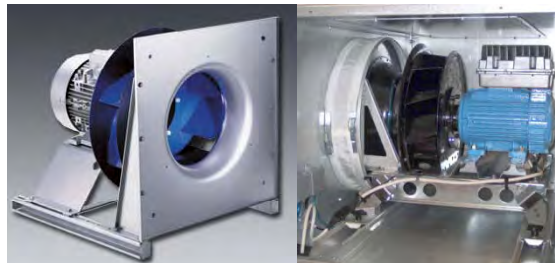

Figure 5- 2: Plenum (plug) mounted centrifugal fans with direct drive [source: Ziehl-Abegg; Swegon]

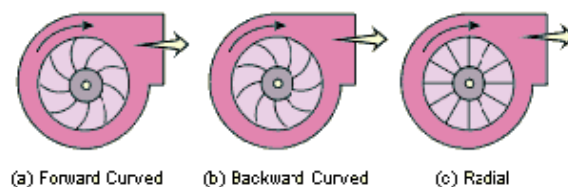

Figure 5- 3: F-wheel, B-wheel and T-wheel centrifugal fans in scroll housing [source: US EPA]

<sup>1</sup> Air Infiltration and Ventilation Centre (see Task 2 report, Chapter 4, for description). Publication: Schild, P.G, Mysen, M., Recommendations on Specific Fan Power and Fan System Efficiency, Technical Note AIVC 65, December 2009.

<sup>2</sup> Eurovent, J. Hoogkamer, pers.comm. Oct. 2010. E.g. air filters and ducts.

<sup>3</sup> Kaup, C., Study on the energy efficiency of air handling units (AHU), paper Birkenfeld Environmental Campus, Trier University of Applied Sciences, Germany, 2010.

B-wheels are the most efficient centrifugal fans. Schild<sup>4</sup> mentions that although they are usually the best choice in terms of energy efficiency, they may have a limited operating range (pressure changes have little influence on flow rate) and are somewhat noisier than F-wheels. In systems with varying flow rate, these fans must be controlled by a variable speed drive (VSD or VFD). They may be installed in *scroll housing* (i.e. a 'blower'; see Figure 5-2 left and Figure 5-3) or *plenum housing* (i.e. a plug arrangement with nozzle/venture /cone inlet, and free outlet; see Figure 5-2 right). Scroll housing gives approx. 10% higher efficiency but is less compact than plenum housing. Double-inlet scrolls achieve the best efficiency of all (i.e. inlet from each side of scroll). On the other hand, connecting sharp bends directly to the outlet gives higher system-effect loss for scrolls than for plenums. Plenum/plug fans have become very popular due to their lower cost, compactness, and flexibility due to the ability to offer different take-offs within a short distance from the fan. Plenum fans suffer from low frequency noise ( $\leq 125$  Hz), due to turbulence in the plenum, at the fan inlet and discharge. This noise is difficult to attenuate.

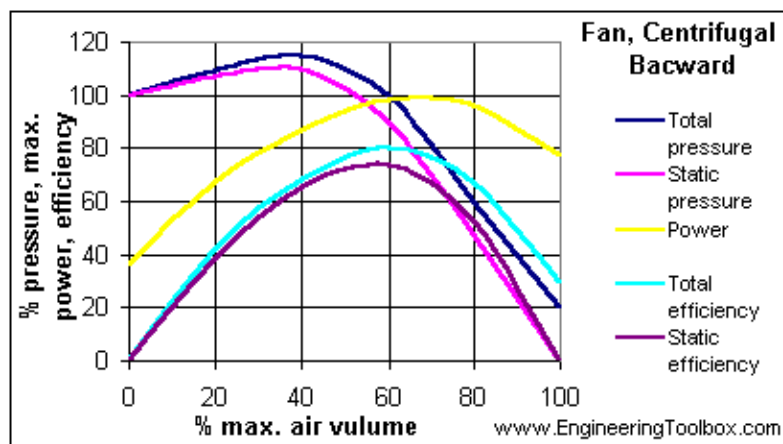

Figure 5- 4: Typical fan curve for B-wheel fan, showing total & static pressure rise, and total & static efficiency. [Source: [www.engineeringtoolbox.com](http://www.engineeringtoolbox.com) ]

F-wheels were traditionally the most common type in ventilation systems in large buildings, but they are inefficient and are thus now pertinent only in special cases. One of the reasons for the commonness of F-wheels, apart from their quietness, was the practice of selecting very compact AHUs (B-wheels need more space for the same flow rate and moderate pressures). T-wheels are also inefficient, but are used in process industry for air loaded with particulate matter, due to their self-cleaning ability. Both F and T-wheels need scroll housing.

*Axial / propeller fans:* See Figure 5-5. These are the best choice for applications with low pressure drop and high flow rate. Axial fans are usually connected directly to the motor shaft, thus avoiding transmission losses [see page 20]. Axial fans are now rarely used in conventional ventilation systems, but are used in systems with very low pressure drop, such as hybrid ventilation. Axial fans are ideal for non-ducted applications, by mounting in a wall ring. They are often mounted with a wire guard grille, which can reduce peak efficiency by 10%.

<sup>4</sup> Schild, P.G., Mysen, M., Recommendations on Specific Fan Power and Fan System Efficiency, Technical Note AIVC 65, December 2009.



Figure 5- 5: (a) axial fan in a wall panel, (b) efficient axial fan with variable-pitch swept blades [source: Ziehl-Abegg]

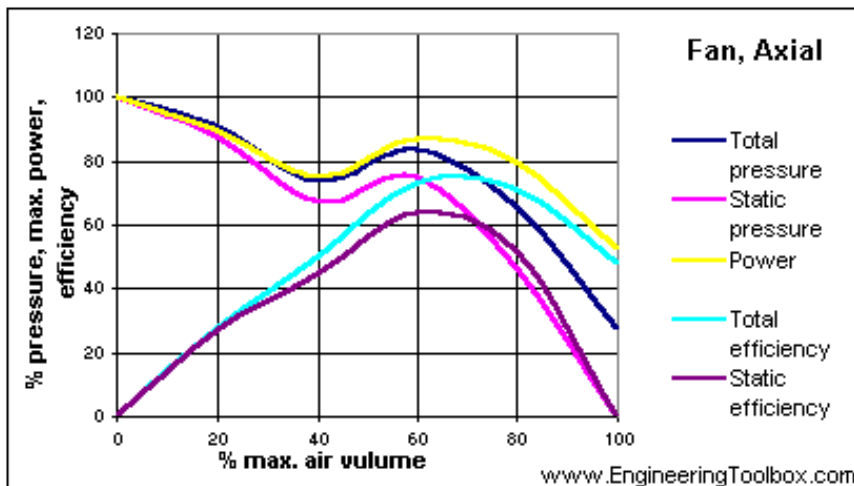

Figure 5- 6: Typical fan curve for axial fan, showing total & static pressure rise, and total & static efficiency. [Source: [www.engineeringtoolbox.com](http://www.engineeringtoolbox.com) ]

Mixed flow / axial-radial / diagonal fans are a relatively new kind that delivers more air than centrifugal fans, and higher static pressure than axial fans. They are directly-driven fans, just as axial fans and centrifugal plug fans. They have less outlet losses than axial fans. This provides more flexibility than with centrifugal or axial fans in relation to fan position, fan outlet (they are ideal for ‘plug’ installation), and design of other components. On the other hand, mixed flow fans are less efficient than B-wheel centrifugal fans.



Figure 5- 7: Mixed flow fan with variable pitch impellers [source: Continental Fan Mfg. Inc.]

*Fans for hybrid ventilation:* Both axial and centrifugal fans may be suitable for hybrid ventilation. Specialized roof-mounted vertical-axis centrifugal fans (Figure 5-8) appear to have an advantage over axial fans in that the fan blades do not obstruct flow in the stack when the fan motor is switched off during periods of adequate natural driving forces (wind and/or stack-effect). The alternative, an axial fan located in the stack or throat of the wind cowl, can cause a significant flow reduction when inoperative, and can emit more noise when operating. On the other hand, the blockage effect of a switched-off fan is irrelevant in the case of ventilation systems with a high pressure drop ( $>10$  Pa) that usually exceeds the available natural driving forces. In this case, fan-assistance is needed all the time, so axial fans will be a better option, as they achieve a higher efficiency (Figure 5-9).



**Figure 5- 8: Two examples of centrifugal fans for intermittently fan-assisted stack ventilation.** The left hand cowl has  $SFP \approx 1$ , and a discharge coefficient of  $0,51 < CD < 0,81$  ( $1,5 < \xi < 3,7$ ) when free-wheeling. The right hand fan has negligible pressure drop when switched off and  $SFP \approx 0,19$  at 10 Pa & 42  $\ell/s$  with 8 W DC-motor fan with system efficiency 5,2%. Peak system efficiency is approx. 6,5% [source: CSR Edmonds; Aereco]



**Figure 5- 9: Example of axial fan for continuous fan-assisted residential stack ventilation.** SFP is 0,04  $kW/(m^3/s)$  at nominal flow 10 Pa & 56  $\ell/s$  with 2  $W^5$  [26 ]. [Source: TNO] EC-motor fan with system efficiency 28%.

<sup>5</sup> Auxiliary energy for DCV controls is 5 W

### 2.2.2 Other strict fan efficiency factors

Other factors that affect efficiency include blade material, profile and shape, hub diameter and the number of blades. In general, aerofoil profiles are most efficient, but curved profiles made of uniform thickness sheet metal are only slightly less efficient. Blade shape is also important, for example the most efficient axial impellers have a curved ‘machete’ or ‘teardrop’ form (e.g. Figure 5b) while flat ‘paddle’ or ‘clover-leaf’ types are inefficient. Clearance between the impellers and fan housing should be small to minimize local recirculation (‘blow-by’).

Having a large number of blades reduces the intensity of stalling (at throttled air flow).

### 2.2.3 Fan size and efficiency

Figure 5-10 shows how peak fan efficiency depends on size. Schild states that “Larger fans are more efficient than smaller ones because losses do not scale up in proportion with size. The impact of mechanical and volumetric losses and viscous forces (Reynolds number) are larger for small fans.” In paragraph 2.2.4 we will revisit this concept.

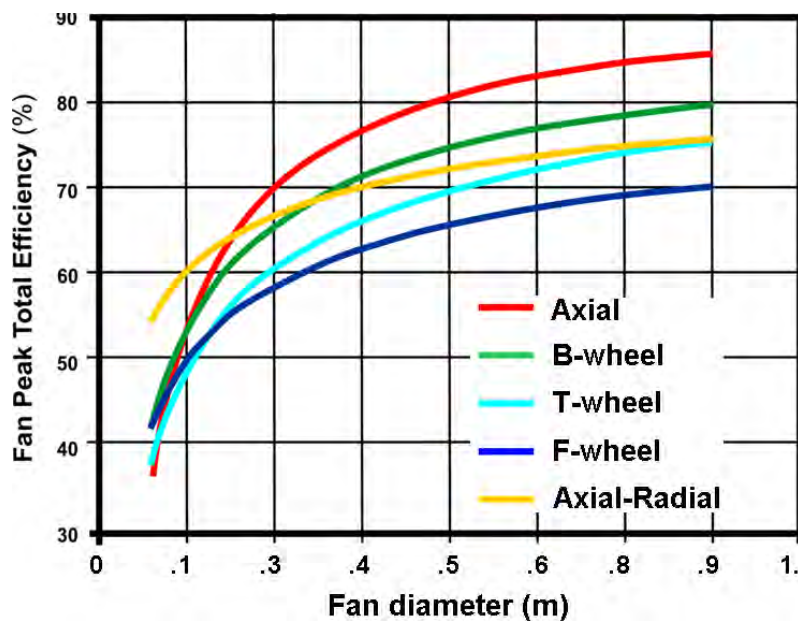

Figure 5- 10: Fan peak efficiency curves. [Source: Engineering & Manufacturing Corp]

### 2.2.4 Sizing for optimum performance and efficiency

Traditionally, when single speed AC motors dominated the ventilation world, the main efficiency-challenge for ventilation system designers was to select a fan with a flow-pressure drop curve that would operate at the so-called ‘best efficiency point’ (bep). This is also demonstrated by the fan curves in paragraph 2.2.2. The bep is situated at the local optimum of the non-linear  $qv-\Delta p$  (flow rate- pressure difference) curve, usually at around two-thirds of the maximum flow rate (at 0 Pa) and maximum achievable pressure difference (at 0 m<sup>3</sup>/h). Depending on the fan design, the efficiency

drops up to 10-20% with respect of its 'best efficiency point' when operated and therefore 'over-sizing' was considered a sin.

This principle, shown in the figure below, is so much enshrined in the hearts and minds of ventilation system designers that it is still the ultimate guidance for fan selection and determines the definition of reference air flows at 65% (residential ventilation unit standards) or 70% (non-residential ventilation unit standards).

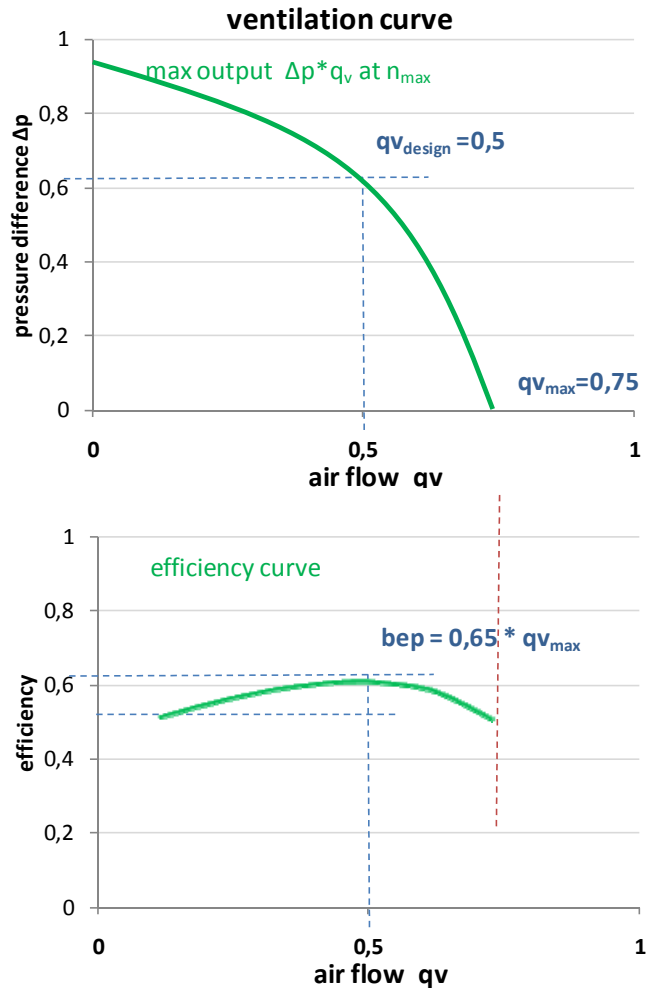

**Figure 5- 11: Best efficiency point (bep) for a single speed fan system.**

Schild<sup>6</sup> mentions that it is important to select the correct size of a fan (i.e. the design air flow and – pressure rise) such that it normally operates at, or near, peak efficiency. This principle is illustrated in Figure 5-12 which shows pressure and efficiency curves for two alternative fan sizes. The larger fan

<sup>6</sup> Ibid. 1

operates at peak efficiency, and achieves the required flow rate at a slightly lower total pressure rise, because the lower outlet velocity reduces system losses at the fan outlet.

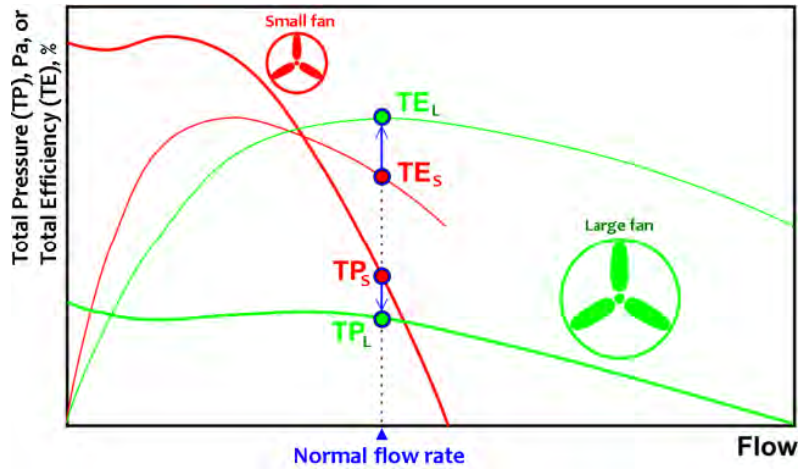

Figure 5- 12: Fan curve illustrating optimum region for supply fan selection. [Source: ACME Engineering & Manufacturing Corp]

For fan systems with variable flow rate, one should consider the entire range of flow rates. The fan size may be optimized by taking into account the amount of time that it operates at different flow rates. This is illustrated in Figure 5-13 for a system with 3 different operation modes. The operating points should ideally not be more than 10% less than the peak efficiency at each fan speed. This 'good' operating region is coloured green. Figure 5-13 also shows fan pressure curves (blue) for 3 different fan speeds, and the efficiency curve (red) for the largest fan speed.

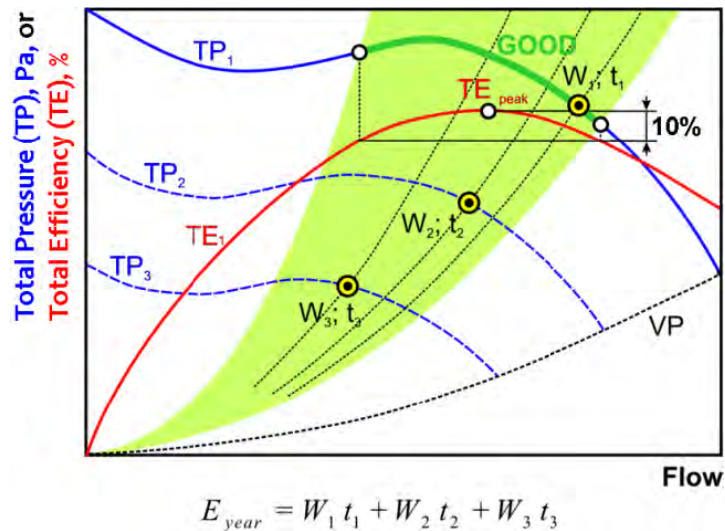

Figure 5- 13: Fan curves. [Source: ACME Engineering & Manufacturing Corp]

Schild<sup>7</sup> states that fans are commonly oversized, such that their peak efficiency occurs at, or near, the 'worst-case' (design) flow rate. Such systems are troubled by low frequency noise (rumbling) when the fan operates at normal or reduced flow rates. This noise is difficult and costly to attenuate. It is better to select a fan size such that peak efficiency is achieved at the most common flow rate.

<sup>7</sup> Ibid. 4

During the short periods of maximum flow demand, the increased fan noise will have a higher frequency, which is much easier to attenuate, using cheaper silencers. Another key reason not to oversize fans is that they can stall or surge<sup>8</sup> at minimum flow demand. Smaller fans have a narrower surge region. These issues are illustrated in Figure 5-14 which shows two alternative fan sizes, of which the smaller one is preferable with regards to acoustics and energy.

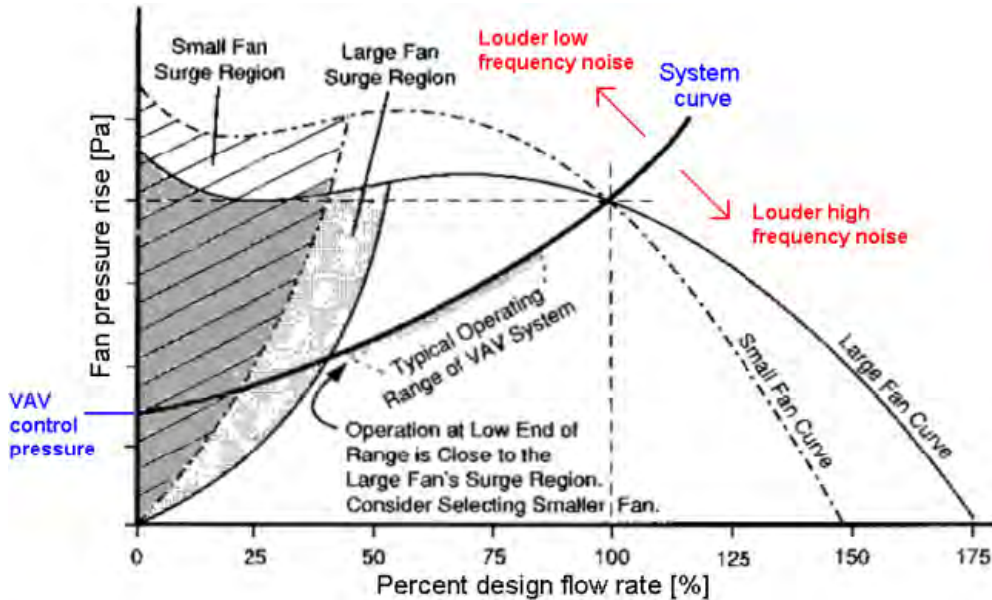

Figure 5- 14: Fan curves: two alternative fan sizes, showing the location of surge regions that should be avoided during part-load operation.<sup>9</sup>

Yet, the entry of variable speed drives may alter the thinking of optimal fan ‘size’, operating point and face velocity in more ways than a simple adjustment of the ideal ‘fixed speed’ curve.

AHU-manufacturers like AL-KO actively promote the energy benefits of ‘low face velocity’, which is another way saying that large, slow fans and large (low pressure drop) filter/ heat exchanger face sections can save enormous amounts of energy and thus money.

Table 5- 1. Key data AL-KO sample

<b>Energy costs (VDI 2067-1)</b>		effective annual interest	5%
heating	0,07 €/kWh	maintenance/service	6%
refrigeration	0,025 €/kWh	<b>price change factors (VDI 2067-1)</b>	
power customer price	0,1 €/kWh	capital	1%
power annual energy price	0 €/kW	energy	5%
energy consumption		operation	1%
humidifier	0,07 €/kWh	repairs	1%
<b>general data years (VDI 2067-1)</b>			
consideration period	15 years		
service life	15 years		

<sup>8</sup> Surge - is the point at which the fan cannot add enough energy to overcome the system resistance. This causes a rapid flow reversal (i.e. surge), vibrations (noise) and of course a low efficiency. Persistent long term operation in the surge region can lead to product failure.

<sup>9</sup> Schaffer, M.E. A practical guide to noise and vibration control for HVAC systems. ASHRAE, Atlanta 1991, pp.56-57

## Unit sizes:

Operating time 24 hours per day, 7 days per week:

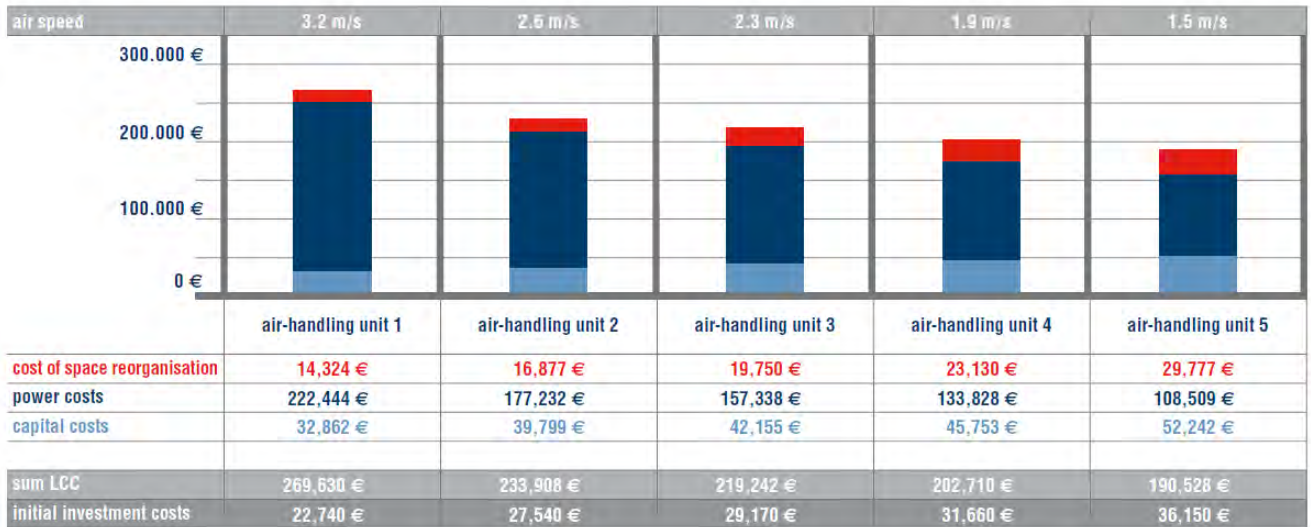

**Figure 5-15. Costs and savings of lowering face velocity** [source: AL-KO]

The AL-KO sample shows considerable energy savings (>50%) and economic savings (LCC drop 30%) by lowering the face velocity.

A face velocity of 1,5 m/s is low for a large AHU, but a small central ventilation unit may have face velocities as low as 0,5 m/s or less and –despite the smaller fan—be more efficient in practice.

Without denying the validity of what is said in par. 2.2.3, it is a legacy concept that “smaller fans are less efficient than large fans”. That may be true for fans tested at rated conditions, but not when the face velocity comes into play.

The critical factor is whether the fan, operating at maximum speed, will still be able to deliver the design air flow at a given external pressure drop and, operating at low speed, be able to stay clear of the surge region.

Figure 5-16 shows a three-dimensional graph of a fan, a representation proposed by Hydeman et al.<sup>10</sup>.

<sup>10</sup> Hydeman, Taylor, Stein, Kolderup & Tong. ‘Advanced Variable Air Volume System Design Guide’, University of California and California State University resource, April 2005 (originally CEC Report P500-03-082-A-11, October 200)

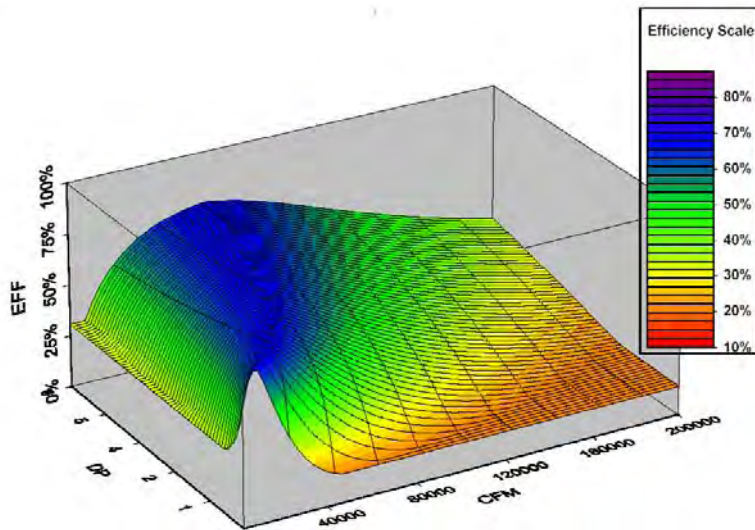

Figure 5-16. 3D curve of pressure (DP), air flow (CFM) and efficiency (EFF) for a 49" housed airfoil fan (Hydeman et al.)

Figure 5-16 shows that, when taking the pressure rise and flow rate both as a variable, the best efficiency area is by no means close to the EN 13799 reference air flow and pressure of 70% of the maximum values.

What can be seen here, are the so-called 'Fan Laws' at work, describing –amongst others– the relationship between volume flow, pressure and absorbed power. An overview is given below

**1. Volume flow:**

$$q_{v2} = q_{v1} \times \left(\frac{n_2}{n_1}\right)^1 \times \left(\frac{d_2}{d_1}\right)^3$$

**2. Pressure:**

$$p_2 = p_1 \times \left(\frac{n_2}{n_1}\right)^2 \times \left(\frac{d_2}{d_1}\right)^2 \times \left(\frac{\rho_2}{\rho_1}\right)^1$$

**3. Absorbed power:**

$$P_{R2} = P_{R1} \times \left(\frac{n_2}{n_1}\right)^3 \times \left(\frac{d_2}{d_1}\right)^5 \times \left(\frac{\rho_2}{\rho_1}\right)^1$$

**4. Density:**

$$\rho_2 = \rho_1 \times \left(\frac{B_2}{B_1}\right) \times \left(\frac{T_1}{T_2}\right)$$

**5. Sound power:**

$$L_{W2} = L_{W1} + 55 \log_{10} \left(\frac{n_2}{n_1}\right)^1 + 55 \log_{10} \left(\frac{d_2}{d_1}\right)^1 + 55 \log_{10} \left(\frac{\rho_2}{\rho_1}\right)^1$$

**6. Efficiency %:**

$$\frac{q_v \times \rho_1 F}{10 P_R}$$

**7. Total pressure:**

$$\rho_1 F = \rho_s F + \rho_d F$$

**8. Velocity pressure:**

$$\rho_s = 0.6 v^2 \text{ (Standard air)}$$

**Nomenclature for symbols used:** $q_v$  = volume flow of air, m<sup>3</sup>/sec $n$  = rotational speed of fan (e.g. in rpm= rounds per minute) $d$  = diameter of fan $p$  = pressure developed by the fan $\rho$  = density of air, kg/m<sup>3</sup> $P_R$  = power absorbed by the fan, kW $L_w$  = sound power level, dB $B$  = barometric pressure $T$  = absolute temperature, K ( $K = ^\circ C + 273$ ) $p_t F$  = fan total pressure, Pa $p_s F$  = fan static pressure, Pa $p_d F$  = fan dynamic/velocity pressure, Pa $p_d$  = system dynamic/velocity pressure, Pa $v$  = velocity of air, m/sec

The Fan Laws show that fan diameter and the rotational speed of the fan play a very important role. The fan diameter ( $d$ ) influences the absorbed power ( $P_R$ ) to the fifth power. For example, a 10% increase of impeller diameter results in a 41% ( $1-0,9^5$ ) energy saving. The fan rotational speed ( $n$ ) influences the absorbed power ( $P_R$ ) to the third power. For example, a 20% decrease of the speed leads linearly to a 20% reduction in air flow, 36% in pressure difference and almost 50% decrease ( $1-0,8^3$ ) in absorbed power.

The diagram below shows this principle, still starting from the bep at maximum speed but then diminishing the speed to 80% of the nominal value.

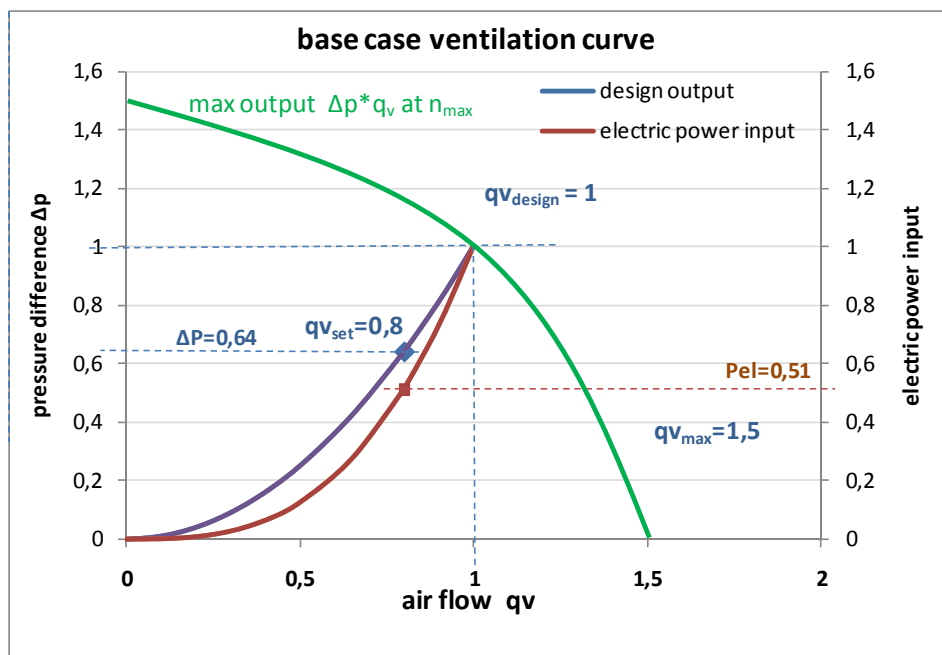

Figure 5-17. Max speed curve (green) plus curves for pressure difference (blue) and absorbed power (brown) when diminishing fan speed/air flow starting from the design operating point.

VHK randomly checked these theoretical data against some catalogue data and –apart from a 3-5% constant—the Fan Laws do apply to the power consumption data found for catalogued exhaust fans and balanced ventilation units, starting from flow rates of 20-25% of the design air flow.

### 2.2.5 Part load system efficiency

At the level of ventilation units performance data there is no doubt that the Fan Laws represent a valid concept and are thus fed into the base cases.

Yet, although it is not in the scope of the study, the question whether savings at the level of the ventilation unit might have negative repercussions at the system level is relevant. And it has to be mentioned that there might be some confusion. Especially if the ventilation system also doubles as an space cooling/heating system, there are many mistakes that can be made at the level of duct design, VAV box control and ATD type, which would neutralize the positive effect of low air flow.

For instance:

- The energy saving only relates to variable speed control systems that are also operated as a variable speed drive. If the VSD fan system is just set at a fixed speed and all the control is done through dampers, there is no effect or even a negative effect (the VSD itself also costs energy).
- Ductwork may be designed in such a way that the fan is forced to operate in the surge region.
- Another example of poor design is the application of constant pressure ATD's. They force the ventilation unit to keep the pressure constant and therefore at best –if there is any positive effect at all—the relationship between power and air flow is just linear. The same goes for VAV box systems designed with constant pressure control. The figure below gives an example.

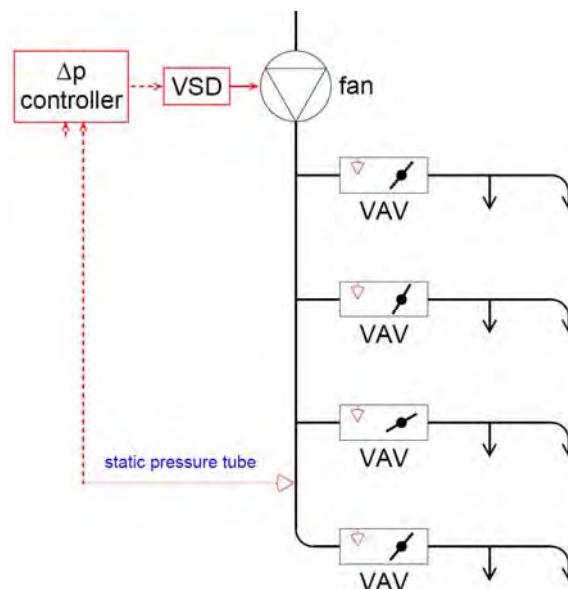

**Figure 5- 18: Illustration of constant static pressure control. Red denotes control system; black denotes duct system. The critical path VAV damper is in max position only at times of maximum flow rate demand. [Source: SINTEF]**

With respect of constant pressure systems, a VAV box system with Static Pressure Reset (SPR) reportedly can save over 50% <sup>11</sup>(See figure below).

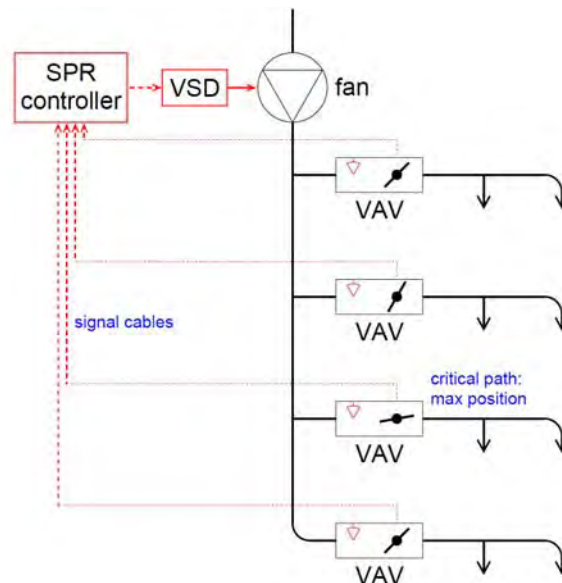

**Figure 5- 19: Illustration of SPR control. At any time, at least one VAV balancing damper is in max position (the critical path). Dampers cannot be 100% opened due to need for control authority, i.e. to prevent excessive servo motor wear due to ‘hunting’**

### 2.2.6 Efficiency rating

The following sub-paragraphs revisit the efficiency and performance parameters for fan systems that were discussed in the Task 1 report, but now from the viewpoint of values that are found in practice. The following ratings are discussed:

- The most comprehensive: fan system efficiency (e.g. used in Ecodesign measures on ‘industrial’ (>125 W) fans ;
- the most popular: Specific Fan Power (SFP) in  $W/(m^3/s)$ ;
- the most likely to be used for (‘domestic’) ventilation units with individual fans <125 W electric power input: Specific Power Input (SPI) in  $W/(m^3/h)$ ;
- the one also taken into account for Ecodesign measures on industrial fans: FMEG;
- rating under the Ecodesign Fan Regulation.

### *Fan system efficiency*

#### Definition

<sup>11</sup> Ibid. 10

Fan system efficiency  $\eta_{tot}$  is defined in EN 13799 based on the efficiencies of the single components (fan, motor, belt drive, speed control, etc.)

$$\eta_{tot} = \eta_{fan} \cdot \eta_{Motor} \cdot \eta_{Drive} \cdot \eta_{Control}$$

$\eta_{fan}$  Fan efficiency

$\eta_{Motor}$  Motor efficiency

$\eta_{Drive}$  Drive efficiency e. g. belt drive

$\eta_{Control}$  Speed control efficiency e. g. frequency inverter

with fan efficiency

$$\eta_{fan} = \frac{q_{fan} \cdot \Delta p_{fan}}{P_{fan}}$$

where

$q_{fan}$  is air flow through the fan in  $m^3 \times s^{-1}$

$\Delta p_{fan}$  is total pressure rise from the fan inlet to the outlet in Pa

$P_{fan}$  is fan shaft electric power demand in W

Values

EN 13799 gives the following 'typical values' (see table).<sup>12</sup>

**Table 5- 2 .Examples for efficiency for specific components in central air system (EN 13799, Annex D, Table D.1)**

Component	Efficiency in %		
	Low	Normal	High
Fan based on total pressure $\eta_{fan}$	65	75	80
Fan based on static pressure*	55	65	70
Motor < 1.1 kW $\eta_{Motor}$	70	77	80
Motor < 3.0 kW $\eta_{Motor}$	75	82	85
Motor < 7.5 kW $\eta_{Motor}$	80	87	90
Motor > 7.5 kW $\eta_{Motor}$	82	89	92
Belt drive < 1.1 kW $\eta_{Drive}$	70	75	80
Belt drive < 3.0 kW $\eta_{Drive}$	75	80	85
Belt drive < 7.5 kW $\eta_{Drive}$	80	85	90
Belt drive > 7.5 kW $\eta_{Drive}$	85	90	95
Flat belt $\eta_{Drive}$	90	93	97
Frequency inverter $\eta_{Control}$	88	92	97
Total fan unit $\eta_{tot}$	50	55	60

\*=see next paragraph for definition. Note that the first row of the table refers to dynamic pressure

Kaup gives the (dynamic) fan efficiency  $\eta_{fan}$  versus the flow rate (in  $m^3/h$ ) as outlined in the graph below, for a population of close to 14.000 AHUs sold in Germany by one up-market manufacturer in

<sup>12</sup> All values are applicable to an air density of  $\rho = 1.2 \text{ kg} \times \text{m}^{-3}$

the period 2003-2009. The graph relates to the supply fan, at average fan efficiency of 69,2%, but the exhaust fan diagram is similar.

The BAT-values (Best Available Technology) are around 83-84% across the whole range of flow rates.

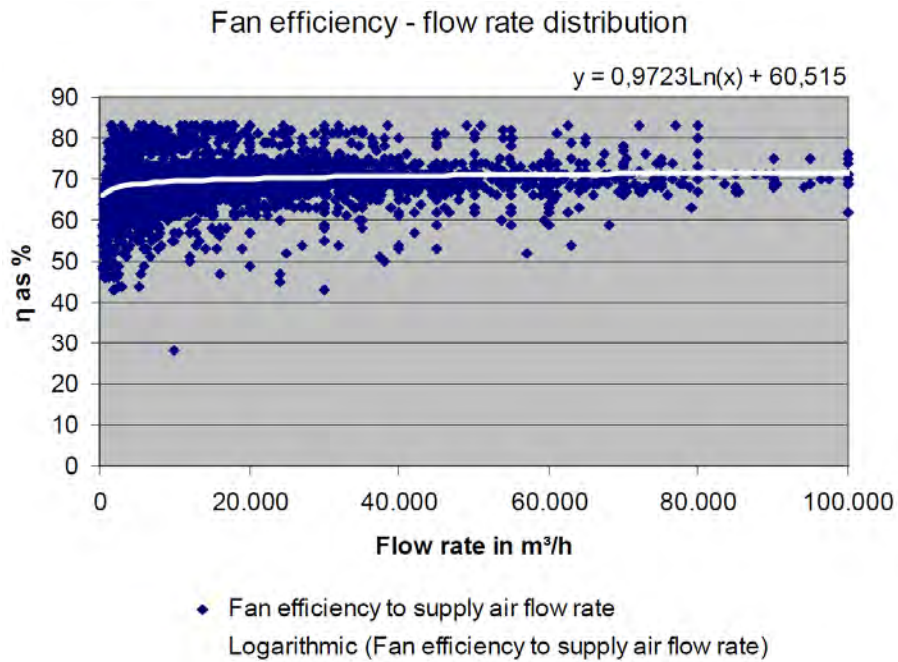

Figure 5-20. Statistical distribution of fan efficiency supply air [source: Kaup 2010]

The same author gives the total system efficiency  $\eta_{tot}$ . On the supply side an average system efficiency of 54,5% was found with an average shaft power ( $q_{fan} \cdot \Delta p_{fan}$ ) of 6,18 kW. On the exhaust air side the average efficiency was 53,8% at an average shaft power of 4,84 kW. The BAT values for total system efficiency are in the range of 65-70% for units above 15-20.000 m³/h. For the smallest units the BAT value in the population of Kaup is around 50-55%.

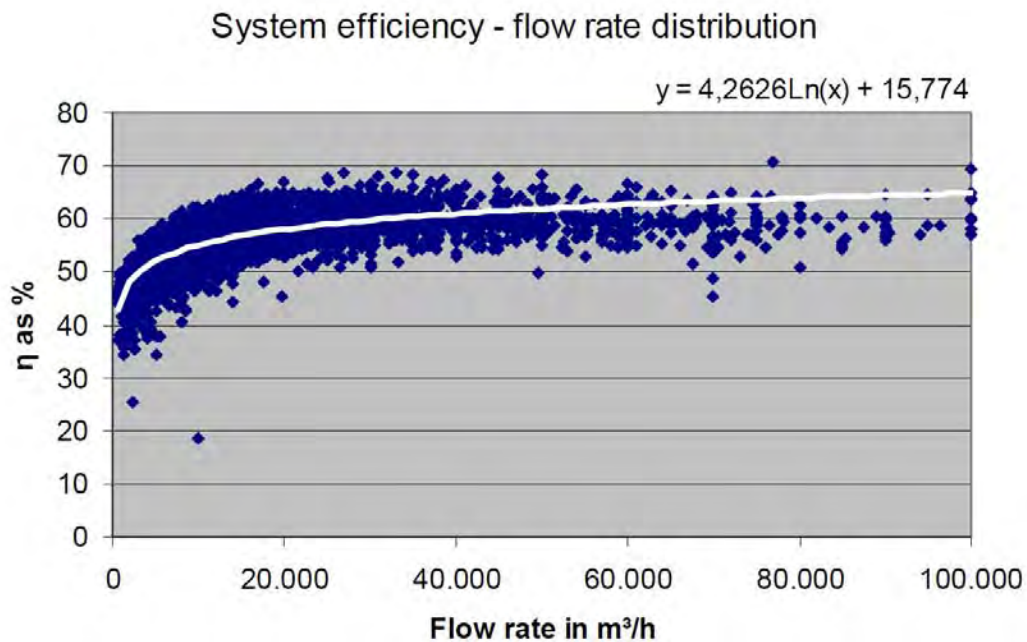

Figure 5-21. Statistical distribution of fan system efficiency supply air [source: Kaup 2010]

The motor and drive efficiency ( $\eta_{Motor} \cdot \eta_{Drive}$ ) was 84,7% (supply air, at 7,3 kW) and 83,8% (exhaust air, at 5,77 kW). Kaup explains this high motor and drive efficiencies because direct drive fan systems have been gaining ground in recent years and this eliminated drive losses.

Note that, as explained in the Task 2 report, the population of Kaup represents the values achieved by an up-market German manufacturer of relatively larger AHUs. In Task 2 the fan system efficiency is estimated at between 45% (AHU 4.000 m<sup>3</sup>/h) and 52% (AHU 35.000 m<sup>3</sup>/h). For heat recovery ventilation units with a design air flow below 2.500 m<sup>3</sup>/h fan system efficiency was estimated at 56%. For exhaust (or supply) units, where a large part of the market uses simple AC motors, the fan system efficiency was estimated at a mere 17%.

### **Specific Fan Power**

In non-residential applications the Specific Fan Power (SFP) in W/ (m<sup>3</sup>/h), as defined in EN 13799, is used (see task 1 report). It takes into account the power consumption of the fan(s)<sup>13</sup>, at a flow rate and external pressure drop that is 65% of the maximum value (at 0 Pa and 0 m<sup>3</sup>/h respectively) if no specific value is supplied by the manufacturer. It may be expressed per individual fan, for the ventilation unit or for the building.

The advantage of SFP-definition is its flexibility over a wide range of pressure differences and a wide range of applications, e.g. collective residential ventilation with varying building heights up to non-residential applications from small shops up to hospitals. The disadvantage is that internal pressure losses, auxiliary energy (e.g. for defrosting) and stand-by electricity (e.g. for controls and CPU) are not taken into account. From the above table it is clear that using the SFP as a single parameter to evaluate the electrical efficiency does not give a complete and correct picture. E.g. the unit with the most efficient fans (AHU-L) has the highest SFP.

Figures for SFP should therefore always be seen in the context of an application.

An audit of nearly 500 balanced ventilation systems in Sweden in 1995 indicated an average Specific Fan Power (SFP<sup>14</sup>) of 3 kW/ (m<sup>3</sup>/s). Studies in other countries have shown similar or higher values<sup>15</sup>. At the other end of the scale, hybrid ventilation systems<sup>16</sup> can use less than 0,1 kW/(m<sup>3</sup>/s). And again, all these values have to be seen in context. Schild mentions for instance that in Norway a ventilation flow rate of 10 m<sup>3</sup>/h per m<sup>2</sup> is a "typical" value for an existing office building in Norway, whereas in other parts of the EU a rate of 1,3 to 1,5 m<sup>3</sup>/h per m<sup>2</sup> is "typical", i.e. according to EN standards.

Nonetheless, SFP is a popular measure for fan efficiency and widely used in national building regulations

In most cases, building regulations set limits on SFP<sub>BLDG,v</sub> for whole buildings at design (maximum) flow rate. Although building regulations do not normally explicitly state so, this is based on the value of SFP<sub>v</sub> for the individual AHUs or fans in the building (i.e. measured with clean air filters and dry coils), to ease on-site verification.

- *UK, 'Part L' of the building regulations (2010):* Exhaust systems: SFP<sub>BLDG</sub> ≤ 0,6 kW/(m<sup>3</sup>/s), Balanced ventilation with heat recovery: SFP<sub>BLDG</sub> ≤ 1,0 kW/(m<sup>3</sup>/s). SFP<sub>BLDG</sub> at 25% of design flow rate should not exceed SFP at 100%. Motors should have efficiency class IE2 (EFF1). FCU

<sup>13</sup> Note that in EN 13799 the SFP may be expressed for individual fans, for the ventilation unit or for the building. In order to stay as close as possible to the residential standard, it is proposed to use SFP per unit.

<sup>14</sup> See §2.2 for definition of SFP

<sup>15</sup> Ibid. 2

<sup>16</sup> Hybrid ventilation = Fan-assisted natural ventilation

systems  $SFP_{FCU} \leq 0,6 \text{ kW}/(\text{m}^3/\text{s})$ .  $SFP_i \leq 0,2 \text{ kW}/(\text{m}^3/\text{s})$  for non-ducted local ventilation (wall fans, even if intermittent operation).

- *Finland (2007)*: Max.  $2,5 \text{ kW}/(\text{m}^3/\text{s})$  for ordinary systems.
- *Sweden (2006)*: Max. values for systems over  $0,2 \text{ m}^3/\text{s}$ : Balanced with heat recovery  $2,0 \text{ kW}/(\text{m}^3/\text{s})$ ; Balanced without heat recovery  $1,5 \text{ kW}/(\text{m}^3/\text{s})$ , Exhaust with heat recovery  $1,0 \text{ kW}/(\text{m}^3/\text{s})$ , Exhaust without recovery  $0,6 \text{ kW}/(\text{m}^3/\text{s})$ . Mandatory inspection scheme ('OVK') includes SFP measurement.
- *Norway (2007)*: Max.  $2,5 \text{ kW}/(\text{m}^3/\text{s})$  for dwellings. Other buildings max.  $2 \text{ kW}/(\text{m}^3/\text{s})$  during working hours;  $1 \text{ kW}/(\text{m}^3/\text{s})$  at other times. Heat recovery is assumed.
- *USA, ASHRAE 90.1 (1999)*: For systems below  $9,4 \text{ m}^3/\text{s}$ : CAV:  $1,9 \text{ kW}/(\text{m}^3/\text{s})$ , VAV:  $2,7 \text{ kW}/(\text{m}^3/\text{s})$ . For systems above  $9,4 \text{ m}^3/\text{s}$ : CAV:  $1,7 \text{ kW}/(\text{m}^3/\text{s})$ , VAV:  $2,4 \text{ kW}/(\text{m}^3/\text{s})$ . Fan efficiency requirements will be added in 2010.
- *USA, California Title 24*: For fans over  $17 \text{ kW}$ : VAV:  $2,7 \text{ kW}/(\text{m}^3/\text{s})$ , CAV:  $1,7 \text{ kW}/(\text{m}^3/\text{s})$ .
- *Germany (EnEV 2007)* sets a limit of  $2 \text{ kW}/(\text{m}^3/\text{s})$  for ventilation units  $>4400 \text{ m}^3/\text{h}$ .

### Specific Power Input

In residential applications (EN 13141, see Task 1 report) the total electricity consumption of the unit is included in the Specific Power Input SPI in  $\text{W}/(\text{m}^3/\text{h})$ , where the flow rate is taken at 70% of the maximum (at 0 Pa) and an external pressure drop of 100 Pa. Between uniform configurations (of fans, filters, heat recovery heat exchangers, etc.) and applications (e.g. whole house ventilation) the SPI is well suited to give an impression of the overall electrical efficiency.

The disadvantage of the SPI is that its use is limited to well-defined applications, like in the residential sector. It is not suited for non-residential applications.

### FMEG

New ISO and AMCA standards have been established to define a classification system for fan systems called '*Fan-&Motor Efficiency Grade*' (FMEG) for fans larger than 125 mm diameter. The curves account for the physical laws governing efficiency of scale, which makes small fans less efficient than large fans of the same design. Well-designed large fan systems can achieve at least FMEG60 (i.e. 60% efficiency for a 10 kW system). FMEG limits can be set in building regulations as minimum energy-performance requirements, but they are a relatively new phenomenon.

The imminent Ecodesign Regulation on industrial fans also implicitly uses the new ISO 12759 and AMCA 205<sup>17</sup> standard on FMEG, because it sets a different target for units up to 10 kW electric motor power input and units above 10 kW.

### Ecodesign Fan Regulation

The imminent Ecodesign Commission Regulation on Industrial Fans (hereafter '*Fan Regulation*'), approved by the Regulatory Committee d.d. 11 June 2010 is applicable for fans with rated electric motor power of 125 W or higher.

It uses the fan system efficiency as a parameter for Minimum Efficiency Performance Standards (MEPS).

---

<sup>17</sup> AMCA 205. Energy efficiency classification for fans

It is based on the ISO 5801 standard for the performance assessment.

The Fan Regulation uses 4 different *measurement categories*, depending on whether the fan inlet and outlet are both free (category A), ducted on the outlet side (B), on the inlet side (C) or ducted on both sides (D). ISO 5801 defines the standard airway (ducts) that allows fans to be tested with harmonized test set-ups. A fan adaptable to more than one measurement category will have more than one performance characteristic.

The Fan Regulation then distinguishes, depending on measurement category, an *efficiency category* which may be based on either *static pressure*<sup>18</sup> or *total pressure*<sup>19</sup>, resulting in either *static efficiency* or *total efficiency*. The Fan Regulation proposes an assessment at the *Best Efficiency Point (BEP)*.

The nominal rated motor efficiency  $\eta_m$  should be determined in accordance with Regulation 640/2009 whenever applicable. If the motor is not covered by Regulation 640/2009 or in case no motor is supplied a default  $\eta_m$  is calculated for the motor using empirical equations given in the regulation.

As regards the use of Variable Speed Drives, the Fan Regulation recognizes that –although in a standard test it may cost some energy- in practice this is an efficient feature and it has introduced a *part load compensation factor*  $C_c$  in the equation for the fan system efficiency. *The drive efficiency*  $\eta_T$  is 100% for a direct-drive, 89% for a ‘low-efficiency drive’ and 94% for a ‘high efficiency drive’.

In case the fan is not put on the market as a ‘*final assembly*’ –not relevant for products in the scope but mentioned to complete the picture—there is a *compensation factor*  $C_m$  in the equation (default 0,9) that account for matching of components.

The Task 1 report, Chapter 3, gives details of the calculation method.

In its target efficiency the Fan Regulation also implicitly uses the new ISO 12759 and AMCA 205<sup>20</sup> standard on FMEG, because it sets a different target for units up to 10 kW electric motor power input and units above 10 kW. Target values for category A,C seem less ambitious than for category B,D , but it must be taken into account that these are efficiencies based on total pressure<sup>21</sup>, i.e. generally 10-15%-points higher than the efficiency values based on static pressure.

The table below gives a selection of the approved Fan Regulation and examples of minimum efficiency targets for several values of the electric motor power P (in kW). Note that categories A/C, BC fans without housing, FC fans and cross-flow fans were omitted because they are not relevant for new ventilation units.

Note that EN 13053 recommends using only BC (backward curved) fans (see Task 1 report)

---

<sup>18</sup> ‘Fan static pressure’ ( $p_{st}$ ) means the fan total pressure ( $p_f$ ) minus the fan dynamic pressure corrected by the Mach factor; ‘Mach factor’ means a correction factor applied to dynamic pressure at a point, defined as the stagnation pressure minus the pressure with respect to absolute zero pressure which is exerted at a point at rest relative to the gas around it and divided by the dynamic pressure; ‘Stagnation pressure’ means the pressure measured at a point in a flowing gas if it were brought to rest via an isentropic process;

<sup>19</sup> ‘Fan total pressure’ ( $p_f$ ) means the difference between the stagnation pressure at the fan outlet and the stagnation pressure at the fan inlet;

<sup>20</sup> AMCA 205. Energy efficiency classification for fans

<sup>21</sup> Dynamic pressure (in Pa) is the pressure derived from the mass flow rate, the average gas density at the outlet and the fan outlet area.

**Table 5- 3. Ecodesign Fan Regulation 2010, summary and examples**

fan type	cat.	press.	range		N	N	P=	EXAMPLES (P in kW)				
			P	$\eta_{target} =$				0,5	1	2,2	7,5	32
			in kW		13	15						
Axial	B, D	total	$P \leq 10$	$2,74 \cdot \ln(P) - 6,33 + N$	50		2013	41	44	46	49	51
			$10 < P$	$0,78 \cdot \ln(P) - 1,88 + N$		58	2015	49	52	54	57	59
BC with housing*	B, D	total	$P \leq 10$	$4,56 \cdot \ln(P) - 10,5 + N$	61		2013	47	51	54	60	62
			$10 < P$	$1,1 \cdot \ln(P) - 2,6 + N$		64	2015	50	54	57	63	66
Mixed flow	B,D	total	$P \leq 10$	$4,56 \cdot \ln(P) - 10,5 + N$	58		2013	44	48	51	57	59
			$10 < P$	$1,1 \cdot \ln(P) - 2,6 + N$		62	2015	59	59	60	62	64

\*\*\*=Centrifugal backward curved fan with housing

cat. B, D=with duct outlet or both duct in/outlet

press. static= static efficiency

press. total= total efficiency

$\eta_{target}$  = minimum efficiency (in %) , equation as function of P (in kW) and N

N= efficiency grade; '13'=applies to tier 1 in 2013; '15'=applies to tier 2 in 2015.

Compare:

Sales 2010 (total; cat. B,D)

18	63	54	58	61
----	----	----	----	----

Stock 2010 (total; cat B,D)

17	56	45	50	52
----	----	----	----	----

Values of P in the examples match those of CEXH, CHRv, AHU-S, AHU-M and AHU-L, given in Task 2.

The Commission expects an electricity saving potential of 5% in 2020 from this generic fan measure (34 TWh/a on a total of 660 TWh/a in baseline 2020). For the application in non-residential ventilation units, where usually the category B, D (with outlet ducts) applies and cross-flow fans are not suitable, it seems that 5% is a conservative estimate.



## 2.3 Motors and Motor efficiency

Motor and drive efficiency is part of the fan system efficiency. This paragraph gives some further discussion on types and characteristics.

### 2.3.1 Motor types

Table 5-4 gives an overview of common types of fan motor.

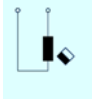
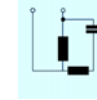
**Table 5- 4: Comparison of features of main motor types used for fans. [source figures EBM]**

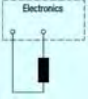
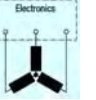
	AC induction motors			EC motors 1	
	Shaded pole	Permanent split capacitor	3-phase induction	Single core	3-core
Circuit design					
Power supply	1-phase AC	1-phase AC	3-phase AC	1-ph. AC or DC	any
Capacity	< 50 W	< 0.5 kW	> 1 kW	< 5 kW	< 5 kW
Integrated VSD	N	N	N	Y	Y
Rotor type	Squirrel cage	Squirrel cage	Squirrel cage	Magnetic rotor	Magnetic rotor
Efficiency	Poor	Medium	Good	Better	Best
Noise	Poor	Medium	Good	Medium+	Good+

Small residential ventilation fans have used traditionally shaded-pole AC motors. These are the least efficient motors but are cheap and reliable. Progressive manufacturers have switched to more efficient and expensive DC motors with electronic commutation (EC<sup>22</sup>). EC motors have integral speed control (VSD) with higher efficiency than VFDs for AC motors. Some small units even have a fan-specific sensorless control algorithm that can maintain constant flow rate or constant pressure rise. These motors have much lower losses than AC induction motors due in part to use of permanent magnets instead of electrical currents in the rotor. There is also no slip in rotor speed, unlike AC induction motors.

Larger motors are traditionally AC induction (asynchronous) motors, of which 3-phase motors with 4-poles are the most efficient. However large EC motors are gaining popularity for both axial and centrifugal plug fans. They cost more than the combined cost of AC motor with VFD, yet have lower LCC due to their higher efficiency, especially under part-load operation. They are also quieter and smaller, enabling shorter AHUs. All the largest motors (either AC or EC) run on 3-phase mains.

**2.3.2 Factors affecting motor efficiency**

The efficiency of electric motors depends on many factors. Figure 5-22 shows how peak motor efficiency depends on size. Larger motors are more efficient than smaller ones because losses do not scale up in proportion with power. For example, magnetic leakage at the ends of stators is scaled by a length-to-volume ratio per unit power, and heat loss is scaled by a surface-to-volume ratio per unit power. For the same reason, small motors have lower part-load efficiency (Table 5- 3).

<sup>22</sup> Brushless DC Motors with permanent magnet rotor (full acronym BLDC), commonly known as 'EC-motors'

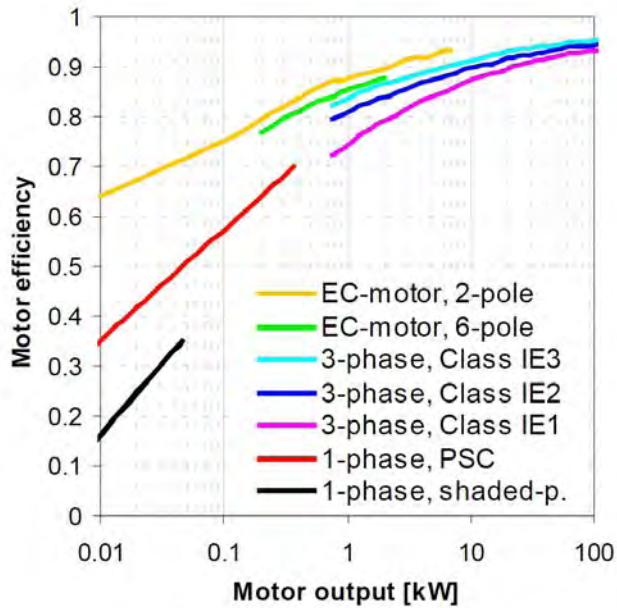

**Figure 5- 22: Peak motor efficiency depending on motor size, for different motor types.** The three IE classes for 3-phase motors are for 4-pole induction motors at 50 Hz (60 Hz motors below 25 kW have approx. 87% of the losses)

### 2.3.3 Sizing and part load performance

Table 5- 23 shows the typical part load performances of different system components of different sizes. Figure 5- 24 illustrates the overall efficiency of a 3-phase AC induction motor together with a VFD. It shows a clear drop below approx. 50% of maximum load.

A motor is oversized if the nameplate power rating is significantly greater than needed. Oversized motors, especially small ones, are less efficient than motors that are suited to the load (Figure 5- 23). The influence of size on efficiency depends on motor type, manufacturer, and must be checked in each specific case. Field measurements have indicated that many fan motors are vastly oversized, and thus very inefficient. Motors should be chosen to operate at peak efficiency at the particular duty point, not be oversized such that efficiency is reduced. For AC motors, the location of the peak efficiency depends on the motor size as shown in Figure 5-23. One should replace a motor with a smaller one if it operates at less than 40% of nameplate rating at design flow rate. It is therefore important to calculate the ventilation system's pressure drop before selecting fans and motors that are tailored to the load. If one is unsure of the operating point, or want flexibility in relation to future changes, or have a VAV system, then one should use a speed control strategy (e.g. VSD) that enables more optimal operation of the motor under all conditions, or if that is not possible then use staged fans ). In such cases, it is important to use components with low losses (high efficiency) over the part-load range. Still, the motor should not be larger than necessary. If one is unsure whether the motor can meet future needs, one should rather size the electrical supply so that the motor can be changed later.

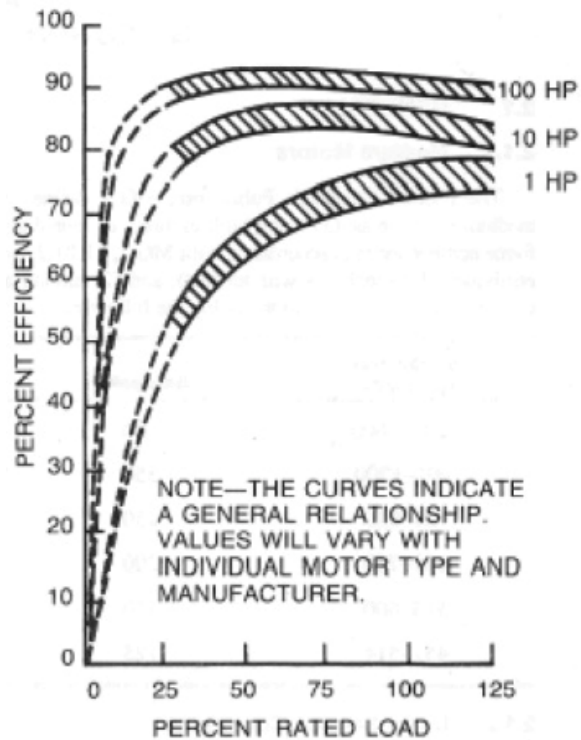

Figure 5- 23: Part-load efficiency curves of 3-phase AC motors [source: NEMA, Standard MG-10]

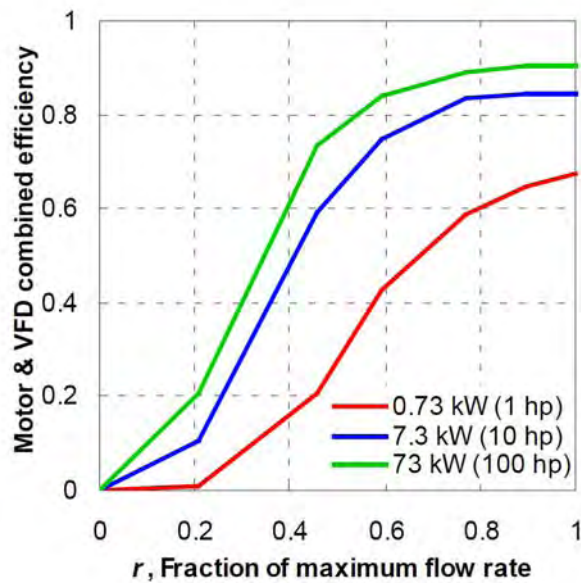

Figure 5- 24: Approximate part-load efficiency curves of the combination of direct-drive AC fan motor and VFD, depending on size (kW). Valid for a typical ventilation system (flow exponent  $n=1,65$  in Eq.4).

### 2.3.4 Motor performance rating

Different laboratory test methods are used for motor performance rating, most notably IEC 60034-2-1 and IEEE 112-B. They measure losses in a slightly different way, which can give up to 1-2 % difference.

Motors can be given an efficiency rating based on the above measurements. Standard IEC 60034-30 defines International Efficiency (IE) classes for 3-phase induction motors over 0,75 kW. The 3 classes are: *IE1* (Standard), *IE2* (High efficiency) and *IE3* (Premium). See Figure 5- 27. A fourth class, *IE4* (Super Premium) will be added in future to rate higher efficiency motors such as EC motors. The standard harmonizes earlier rating schemes such as

European CEMEP<sup>23</sup> (Their *EFF1* rating is equivalent to *IE2*) American NEMA<sup>24</sup> (Their '*NEMA Premium*' rating is equivalent to *IE3*) and the mandatory American Energy Policy Act (The '*EPAct*' rating is now equivalent to *IE2*).

Most industrial states have implemented, or soon will implement mandatory minimum energy performance standards (MEPS) for large electric motors. The first country to do so was the USA in 1997. The European Commission (EC) decided to phase in MEPS from 2011 as part of the Energy-using Products Directive (EuP). By 2011 these countries will generally require minimum class *IE2*. By 2017, both USA and EU will require *IE3* (Premium efficiency). The changes may potentially save 135 TWh/yr in EU in 20 years, equivalent to Sweden's annual electricity use. The global savings potential is a staggering 1850 TWh/yr, or 9,7% of global electricity production. Additional savings are achievable as a result of future MEPS for other components, including fans and VFDs.

---

<sup>23</sup> Committee of European Manufacturers of Electrical Machines and Power Electronics

<sup>24</sup> National Electrical Manufacturers Association

### 2.3.5 Power transmission (drives)

Large fans in old ventilation systems are generally belt-driven, that is, the motor torque is transferred to the fan by a rotating belt (Figure 5- 1). A disadvantage of belt operation is that it incurs energy loss of over 10 % if poorly designed or maintained, and the losses are substantially higher at low load. Flat belts have lower loss than V-belts. Moreover, particles from belt-wear can pollute the supply air. Because of these particles, there should be a fine air filter downstream in the supply air path. Belt operation makes it possible to change the fan speed by adjusting the exchange ratio between the motor and fan, however this function was made redundant by the advent of electronic speed control (VSD).

Modern fans are generally direct-driven, that is, the fan sits on the motor shaft. Direct-drive fans avoid transmission energy losses. Large direct-drive fans usually have VSD. For AC motors this is costly and incurs a similar loss to belt operation. However, VSD provides a number of advantages:

- The ability to regulate the amount of air to a minimum level, instead of shutting off air flow completely. This may reduce the risk of microbial growth and wear on the unit.
- Demand-controlled ventilation
- The possibility of intensive ventilation in periods with cooling demand
- Optimal efficiency of the fan motor

### 3. Fan in- and outlet, filters

#### 3.1 Total system pressure drop – Rules of thumb

The single most important means of reducing fan power is by minimizing flow resistance.

Table 5-5 lists some rule-of-thumb component pressure drops in conventional mechanical ventilation systems in large buildings.

**Table 5- 5: Rule-of-thumb component pressure drops for large buildings**

	Poor design	Typical design	Good design	
Face velocity	2.5	2.0	1.5	m/s
Filter EU3 bag	80	70	50	Pa
Filter EU5 bag	140	115	75	Pa
Filter EU9 bag	190-250	160	110	Pa
<b>AHU</b> Rotary heat exchanger	200-250	150	90-100	Pa
Heating battery	120	80	40	Pa
Cooling battery	140	100	60	Pa
Humidifier	60	40	20	Pa
Fan silencer	80-235	50	30	Pa
Total AHU internal $\Delta p$	670	420	250	Pa
<b>Air distribution</b> Ductwork (supply or exhaust)	300-490	200-230	100-115	Pa
Duct silencers	15	10	0	Pa
VAV box	112	112	25	Pa
Terminal reheat battery	105	50	0	Pa
Plenum box	100	50	30	Pa
ATD (supply or exhaust)	70	50	20	Pa
Exhaust stack/jet	175	175	175	Pa
Fan system efficiency	40 %	50 %	63 %	%
SFP	6	3	1.3	kPa

Table5-6 shows the application of aggregating component pressure drops in a specific building with balanced ventilation and heat recovery. It illustrates that the total pressure loss though ventilation systems is roughly shared equally between the AHU and the distribution system. Much of the pressure drop can be avoided by astute aerodynamic design and by selecting an AHU with larger cross sectional area.

In hybrid ventilation systems, the contribution from natural driving forces (wind and stack effect) accounts for less than 1% of the energy savings in comparison to conventional ventilation systems with high pressure loss. The remaining 99% of the savings is actually a result of reduced flow resistance. Furthermore, all ventilation systems, irrespective of flow resistance, can potentially experience and exploit the same natural driving forces. Hybrid systems can therefore equally be called ‘very low pressure loss’ systems.

**Table 5- 6: Example of aggregating component pressure drops through a ventilation system in a large building, at design flow rate.**<sup>25 26</sup>

		Poor design	Good design	Hybrid vent.	
Supply	Distribution	Inlet louvre & duct	70	25	0
		Filter section F5-F7*	250	50	27
	AHU	Heat exchanger	250	100	13
		Heating coil	100	40	0
		System effect, →fan	30	0	0
		Silencer/attenuator	200	0	0
		System effect, fan→	330	0	0
	Distribution	Supply ductwork	150	100	1
		Terminals (ATD)	50	30	12
	Distribution	Terminals (ATD)	30	20	0
Extract ductwork		120	80	1	
Exhaust	AHU	Silencer/attenuator	100	0	0
		Filter section F5-F7*	250	50	0
	Heat exchanger	250	100	13	
	System effect, →fan	30	0	0	
		System effect, fan→	330	30	0
Distribution	Outlet duct+louvre	250	20	17	
A: Sum distribution syst.		Pa	1330	305	31
B: Sum AHU		Pa	1460	340	53
C: Natural driving forces		Pa	ignored	ignored	-4
Sum Total (A+B+C)		Pa	<b>2790</b>	<b>645</b>	<b>84</b>
Fan system efficiency		%	<b>28 %</b>	<b>63 %</b>	<b>40 %</b>
SFP		kW/(m <sup>3</sup> /s)	<b>10</b>	<b>1</b>	<b>0.2</b>

\* Final filter pressure drop before replacement

Systems in single family housing typically have lower pressure loss due to air distribution than indicated above. Good-practice systems typically have ~70 Pa external pressure drop in supply or exhaust duct systems.

In comparison, EN 13799 gives the following pressure drop table.

**Table 5-7. Examples for pressure drops for specific components in air handling systems (acc. table A.8 of EN13779, extract from Task 1, Table 1-33)**

Component	Pressure losses in [Pa]		
	Low	Normal	High
Ductwork supply	200	300	600
Ductwork exhaust	100	200	300
Heating coil	40	80	100
Cooling coil	100	140	200
Heat recovery unit H3 <sup>1)</sup>	100	150	250
Heat recovery unit H2 – H1 <sup>1)</sup>	200	300	400
Humidifier	50	100	150

<sup>25</sup> K. Mehlsen, Eleffektiv dimensionering af ventilationsanlaeg (Electricity-efficient design of air-handling systems), Report to the Danish National Board of Buildings, by Crone and Koch, Rådgivande Ingeniørfirma A/S, Charlottenlund, Denmark, 1989 (in Danish). Published in Schild (ibid. 1)

<sup>26</sup> Wachenfeldt, B.J. & P.O. Tjelflaa. 'Field Measurements of Pressure Characteristics for Components in a Hybrid Ventilation System'. Int. J. Ventilation. Vol.3 (2005), No.4, pp.295-306. Published in Schild (ibid. 1)

Air washer	100	200	300
Air filter F5 – F7 per section <sup>2)</sup>	100	150	250
Air filter F8 – F9 per section <sup>2)</sup>	150	250	400
HEPA filter	400	500	700
Gas filter	100	150	250
Silencer	30	50	80
Terminal device	30	50	100
Air inlet and outlet	20	50	70
<sup>1)</sup> Class H1 – H3 according to EN 13053 <sup>2)</sup> Final pressure drop before replacement			

## 3.2 Fan inlet and outlet – Aerodynamic inefficiencies

### 3.2.1 General

Fans are tested in laboratories under optimal conditions that can be unachievable in real buildings. In practice, one can expect 10% higher pressure loss (30 Pa for each fan in a large system) due to fan inlet and outlet losses, but poor design can result in at least 75% higher losses (several hundred Pascal in a large system). These losses are collectively called ‘system effects’, and are caused by swirl in fan inlet, pressure drops at the fan inlet and outlet, and additional pressure loss downstream of the fan before the velocity profile has diffused. The final selection of fan and motor can only be done after the calculated pressure drop has been corrected for system effects.

System effects are calculated by the following formula:

$$\Delta p = C \cdot p_d = C \cdot \left(\frac{1}{2} \rho \cdot v^2\right)$$

where

$\Delta p$  = system effect [Pa]

$C$  = system effect coefficient [dimensionless]

$p_d$  = velocity pressure at fan inlet or outlet [Pa]

$\rho$  = air density [kg/m<sup>3</sup>]

$v$  = nominal velocity (volume flow rate / area) [m/s]

### 3.2.2 Recommendations for fan inlets

Schild gives the following recommendations for fan inlets:

- Should have a swirl-free (spin-free) symmetrical fully-developed velocity profile, without flow obstructions.
- For fans housed in a plenum, the minimum distance from the fan inlet to the nearest plenum wall should be greater than 0,75 times the fan inlet diameter.
- The inlet duct’s cross-sectional area should be 92%~112% of the fan inlet area.
- There should be a straight inlet duct of at least 3 times the length of its hydraulic diameter (depending on speed). If this is not possible, then square duct bends should have turning vanes to prevent spin. Circular duct bends should have an inner radius at least as large as the duct diameter. Flow straighteners such as filters, coils or heat exchanger reduce the inlet system effect.

- Flow obstacles such as dampers and tees should not occur near the fan inlet.
- Avoid air spin at the inlet. Equi-rotation (i.e. air spin in the same direction as fan rotation) can reduce fan pressure (Figure 5-25). Contra-rotation is also undesirable as it increases fan noise and energy use.

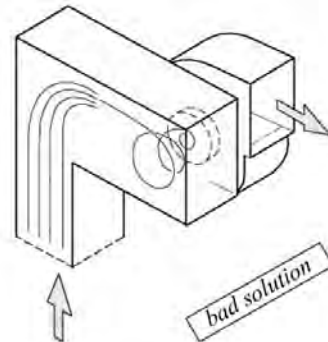

**Figure 5- 25: Example of poor design that generates spin in the same direction as fan rotation.** Add turning vanes in the bend to reduce spin. [Source: Svenska inneklimatinstitutet & SINTEF]

### 3.2.3 Recommendations for fan outlets

Schild gives the following recommendations for the design of fan outlets:

- Aim to create a spin-free symmetrical fully-developed velocity profile, without flow obstructions.
- The connecting duct should ideally be straight, enabling the distorted velocity profile to diffuse, giving a gradual exchange of the high velocity at the fan outlet into useful static pressure<sup>27</sup> (See Figure 5-26). The duct length should be at least 2,5 times the hydraulic diameter (preferably > 6 diameters, depending on speed). See Table 4 for the effect of shorter lengths.
- If sizes of the fan outlet and connecting duct are different, then use a gradual transition. Reduction of the duct cross-section at the fan outlet generally creates less pressure loss than an increase (an évasé or diffuser). Reduction of the outlet duct cross-section should have an angle of max. 30° between the opposite duct walls (Figure 5-27). A divergence (évasé) should have a maximum angle of 15° between opposite duct walls. Avoid 90° bends; use rather 45° bends.
- If a bend is necessary, it should follow the direction of air flow out of the fan. See for example Figure 5-27 and Figure 5-28.

<sup>27</sup> This is called *static pressure regain*

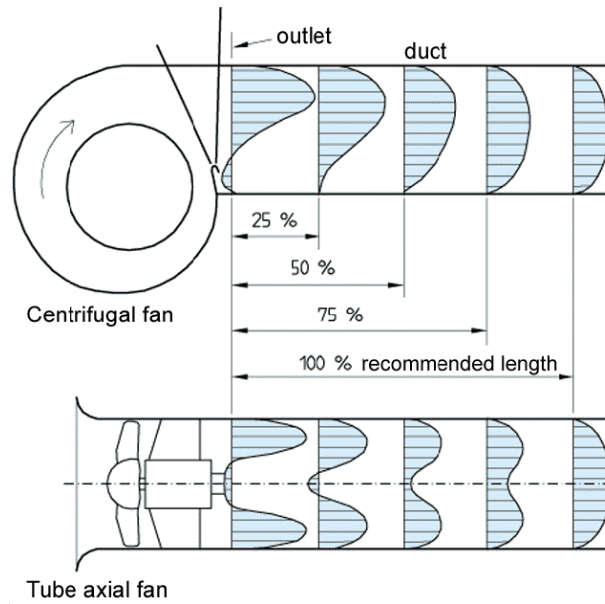

**Figure 5- 26: Velocity profile at outlets of centrifugal and axial fans.** Outlet ducts should have a straight length of at least 2,5 times the hydraulic diameter to allow the velocity profile to diffuse, giving static regain, i.e. higher static pressure but lower velocity pressure. [Source: Svenska inneklimatinstitutet & SINTEF]

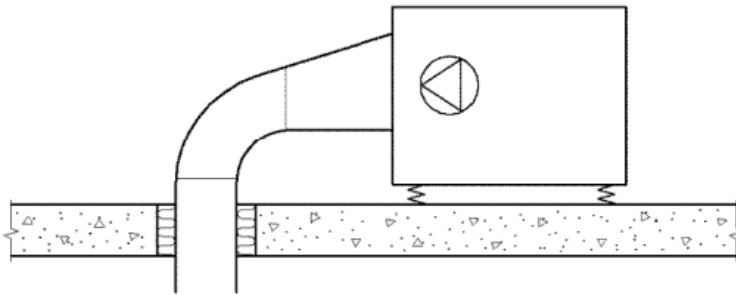

**Figure 5- 27: Example of a fan outlet with a reduction giving a satisfactory transition angle ( $<30^\circ$ ), and a bend that follows the air spin and the eccentric reduction.** [Source: Svenska inneklimatinstitutet & SINTEF]

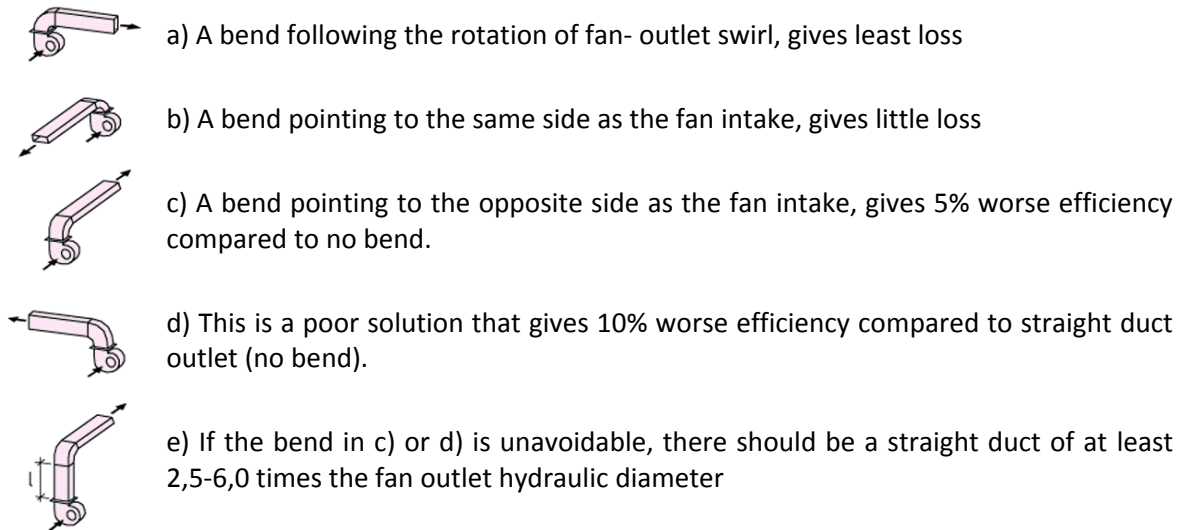

**Figure 5- 28: Impact of the efficiency of different outlets from centrifugal fans.** [Source: Svenska inneklimatinstitutet & SINTEF]

## 3.3 Filters

### 3.3.1 Filter types and their aerodynamic properties

Air filters have two functions. They clean the supply air and protect the ventilation unit components from soiling, especially the heat exchangers and fans. The pressure drop over filters gradually increases as they become dirty, and can exceed 250 Pa. Filters therefore constitute a large portion of the pressure drop in the ventilation system.

Normally, the supply air is 'clean', which is in fact the whole point of ventilation. Nevertheless, 'normal' circumstances are becoming increasingly rare. The monitoring obligations following the EU Air Quality directive have made policy makers and the general public aware that especially in densely populated urban areas the concentration of e.g. 'fine dust' (particulate matter, PM10 and PM 2,5) is frequently above the sustainable health limits defined in directive 1999/30/EC. These particles, in themselves and as carrier particles, play a role in respiratory diseases, asthma, lung cancer, etc..

At the same time, the number of sufferers of allergies and the abovementioned diseases is growing in Europe. In the Netherlands alone it concerns over 10% of inhabitants, which translates into over 20% of households where at least one family member would be affected and that could benefit from adequate filtering and ventilation.

All in all, it is common practice in both residential and non-residential applications to apply at least a fine dust filter (F7) on the supply air and, to promote the long-term effectiveness of the components, at least a coarse filter (G4 but increasingly also F7) on the exhaust side. A common practice –but from the point of view of energy efficiency and economics questionable—is to have a 2-stage filtering on the supply side, with a coarse filter preceding a fine dust filter in order to increase longevity of the latter.

### 3.3.2 Filter types

For comfort-ventilation three main types of filter-principles can be distinguished:

- Mechanical filters,
- Electrostatic filters and
- Gas adsorption ('carbon') filters

In general ventilation, **mechanical filters** are the most commonly used. Basically, they capture the particles that do not bounce off in openings that are big enough to let the air through and small enough to capture certain particles. After capturing they try to hold on to the particles to avoid re-emission. They constitute a significant barrier in the air-stream and –as they get clogged up– they block not only more particles but also the air flow ( $m^3/h$  as depending on the pressure drop over the filter in Pa). The most common design is a 'bag filter', allowing maximization of the filter surface. Bags with a tapered stitch form (i.e. cross-section 'VVV...' as opposed to 'UUU...') allow more uniform air flow through the filter bag area, and thus lower pressure drop.

**Electrostatic filters** come in different forms and shapes but basically work with the principle that the particles go through relatively large and long 'tunnels' causing a minimal pressure drop all throughout their duty life. The 'tunnels' are electrically charged and attract the also charged particles, which then adhere to the tunnel walls. The chances that a particle is –and stays– captured depends on the particle characteristics (size, weight, electrical properties, etc.), the electrostatic charge of the filter and the time the particle is exposed to this electrical charge. The latter depends

on the length of the 'tunnel' and the speed of the particle. In other words: The thickness of the filter and the air speed (in m/s) are of paramount importance for the performance. Contrary to most mechanical filters, the electrostatic filter is not very selective, but works over a broad range of particle sizes. At the end of duty life the extra pressure drop is negligible, i.e. the air flow stays roughly the same throughout product life. At end-of-life the captured particles reduce the filter's electrostatic charge and thereby its ability to capture new particles.

**Gas adsorption filters** are better known as 'activated carbon' filters. The very large surface in high-porosity carbon binds gas and vapour molecules. They are used to capture odours, volatile organic compounds and fractions of petrol fumes. Without a regeneration process, the effective duty life of an adsorption filter is short.

For special applications, large combustion plants and other process applications, i.e. outside the scope of the study, **electrostatic precipitators** (ESPs) are used. There are different types of EPS filters. They generally have a lower pressure drop than bag filters, and are therefore more energy-efficient. Another benefit is that they are highly effective, and are less likely to harbour bacteria than bag or HEPA filters. Typical problems with EPS filters are that they let large particles pass, and lumps of charged particles can separate from the electrode and enter the supply air. One possible solution to this is to allow air to pass through a chamber at low velocity after the filter, such that large particles and lumps fall to the floor of the regularly cleaned chamber. Another solution is to use a coarse filter before the electrostatic precipitator. Precipitators are also known to produce toxic ozone and NO<sub>x</sub> to different degrees. Nevertheless, the indoor concentration of ozone can still be below outdoor concentrations.

### 3.3.3 Filter effectiveness

The effectiveness of an air filter in practice can be expressed as Clean Air Delivery Rate (CADR), which is a function of the filters' functional efficiency and the delivered air flow by the filter apparatus. As a simplified example: A device that delivers 100 m<sup>3</sup>/h with 45% of particles removed has the same CADR as a filter delivering 50 m<sup>3</sup>/h at 90% efficiency.

With any ventilation fan, the resulting airflow depends on the pressure drop caused by the filter. Therefore, filter material manufacturers specify the pressure drop at various given flow rates. The diagram below gives an example of pressure loss of typical mechanical filters –G3 coarse filter and F5 fine filter– and an electrostatic filter as a function of face velocity.

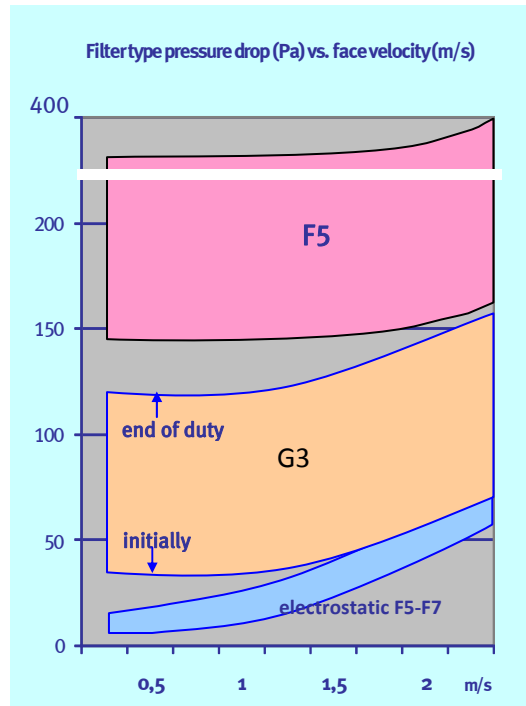

**Figure 5-29. Filter types and pressure drop, in Pa vs. fan velocity in m/s. [VHK on basis of industry data]**

### 3.3.4 Filter efficiency

European standards EN-779 and EN-1822 define filter efficiency classes EU1 to EU18 for mechanical filters.

Class EU1 to EU4 defines coarse filter classes, better known as **G1** to **G4**. The G classification is determined by the overall gravimetric efficiency (mass retained) which is mainly determined by particles of 1 micron ( $\mu\text{m}$ ) upwards. The efficiency is measured at several intervals until the pressure drop reaches a level of 250 Pa (Pascal). Filters of type G2 or G3 are mostly used in residential ventilation systems. Table 1 gives examples of particles that are retained. Lower limits of G-classes are 50/65/80/90%.

Fine filters EU5 to EU9 (**F5** to **F9**) relate to the efficiency in capturing particles of 0,4 micron ( $\mu\text{m}$ ) and the efficiency is measured with an optical particle counter (OPC) up to a pressure drop of 450 Pa. Lower limits of F-classes are 40/ 60/ 80/ 90/ 95%.

Table 5- 8. Air Filter Classes

Standard EN 779 : 2002		Examples of matter retained per filter class
Coarse > 1 µm	G1 EU1	Leaves, insects, textile fibres, human hairs, sand, fly ash, water droplets
	G2 EU2	
	G3 EU3	Beach sand, plant spores, <b>pollen</b> , fog
	G4 EU4	
Fine 0,4 µm	F5 EU5	Spores, cement dust (coarse fraction), sediment. dust
	F6 EU6	Bigger bacteria, germs on carrier particles, <b>PM 10</b>
	F7 EU7	Agglomerated soot, lung damaging dust ( <b>PM 2.5</b> ), PM 2.5-dust, cement dust
	F8 EU8	
	F9 EU9	Tobacco smoke (coarse fraction), oil smokes, bacteria
Standard EN 1822 - 1		
HEPA 0,3 µm	H10 EU10	Germs, tobacco smoke, metallurgical fumes, viruses on carrier particles, carbon black
	H11 EU11	
	H12 EU12	Oil fumes, metallurgical fumes, sea salt nuclei, viruses, radioactive particles, all air suspended PM
	H13 EU13	
	H14 EU14	filter Cleanroom ISO 4, operating theatres in hospitals
ULPA 0,12 µm	U15 EU15	filter Cleanroom ISO 3
	U16 EU16	filter Cleanroom ISO 2
	U17 EU17	filter Cleanroom ISO 1
	U18 EU18	
Gas adsorption		
A gas	Activated carbon	VOCs, tar/ petrol fumes, solvent vapour, odours
	Impreg. Act. Carbon	Acidic gases, SO <sub>x</sub> , NO <sub>x</sub> , HCl, H <sub>2</sub> SO <sub>4</sub> , H <sub>2</sub> S, HF, Cl <sub>2</sub>
	Imp. Act. C-polymers	Amines, NH <sub>3</sub> , NH <sub>4</sub> , NMP, HMDS

Filters class EU10 to EU14 describe the so-called **HEPA** (High Efficiency Penetration Air) filters which are used in the pharmaceutical and food industry, hospitals, etc. The test is described in EN 1822-1 and the classification is based on the efficiency in capturing particles of 0,3 µm. Lower limits of the H10 to H14 classes are 85/95/99/99,5/99,95%.

**ULPA** (Ultra Low Penetration Air) filters are used almost exclusively in clean rooms of the electronics industry and are tested on their efficiency in capturing 0,12 µm particles. Efficiency limits are from 99,995% upwards.

Although it is not mentioned explicitly, the EN 779 and EN 1822-1 **apply only to mechanical filters**, typically in larges air conditioning and air treatment installations that can be found e.g. on the rooftops of large buildings. The test rig is set up for an air duct of 61 x 61 cm section and the default air flow is 3.400 m<sup>3</sup>/h (face velocity 2,5 m/s). Coarse filters G-class should be tested up to a pressure drop of 250 Pa and Fine filters (F-Class) up to 450 Pa. Both values are relatively high compared to real-life. EN 13799 mentions typical pressure drop values for filters (see table 5- 9)

**Table 5-9. Examples for pressure drops for specific components in air handling systems (extract from acc. table A.8 of EN13779, copy of Task 1, Table 1-33)**

Component	Pressure losses in [Pa]		
	<i>Low</i>	<i>Normal</i>	<i>High</i>
Air filter F5 – F7 per section <sup>2)</sup>	100	150	250
Air filter F8 – F9 per section <sup>2)</sup>	150	250	400
HEPA filter	400	500	700
Gas filter	100	150	250

EN 13503 stipulates that *the pressure loss of a filter section loaded with dust shall not exceed the values given in Table 9. Lower final pressure drops can be also specified where appropriate. Filters installed in air handling units used for human occupancy shall be tested and classified according to EN 779*”

**Table 5-10 . Maximum final pressure drop for filters (EN 13503. Table 9)**

Filter class	Final pressure drop
G1 -G4	150 Pa
F5 -F7	200 Pa
F8 -F9	300 Pa

EN 13503 notes that the final pressure drops tabulated in Table 9 are the typical maximum values for air-handling units in operation and lower than those used in EN 779 for classification purposes, for reasons of energy saving, and the performance obtained from tests according to EN 779 are not necessarily met at these lower pressure drops.

### 3.3.5 Electrostatic filter testing

As a case in point that the aforementioned standards only apply to mechanical filters, the standards explicitly mentioned that the filters should be treated before testing *“to eliminate any electrostatic charge”*. For electrostatic filters thus only a coarse filter remains. Furthermore, the pressure drop for electrostatic fine dust filters is far below 450 Pa. The latest generation electrostatic bag filters, at a typical face velocity as in EN 779, reach initial pressure drops as low as 65-70 Pa, running up to around 100 Pa at the end of a 2.000 h duty life. At lower face velocities, typically in smaller installations, the initial pressure drops can be as low as 10-20 Pa, going up to 40-50 Pa at the end of duty life.

As regards the electrostatic filter efficiency, it should be noted that electrostatic filters do not (only) work as a ‘maze’ like the mechanical filters, but typically demonstrate a range of efficiencies at different particle sizes. The diagram below shows an example of an electrostatic filter.

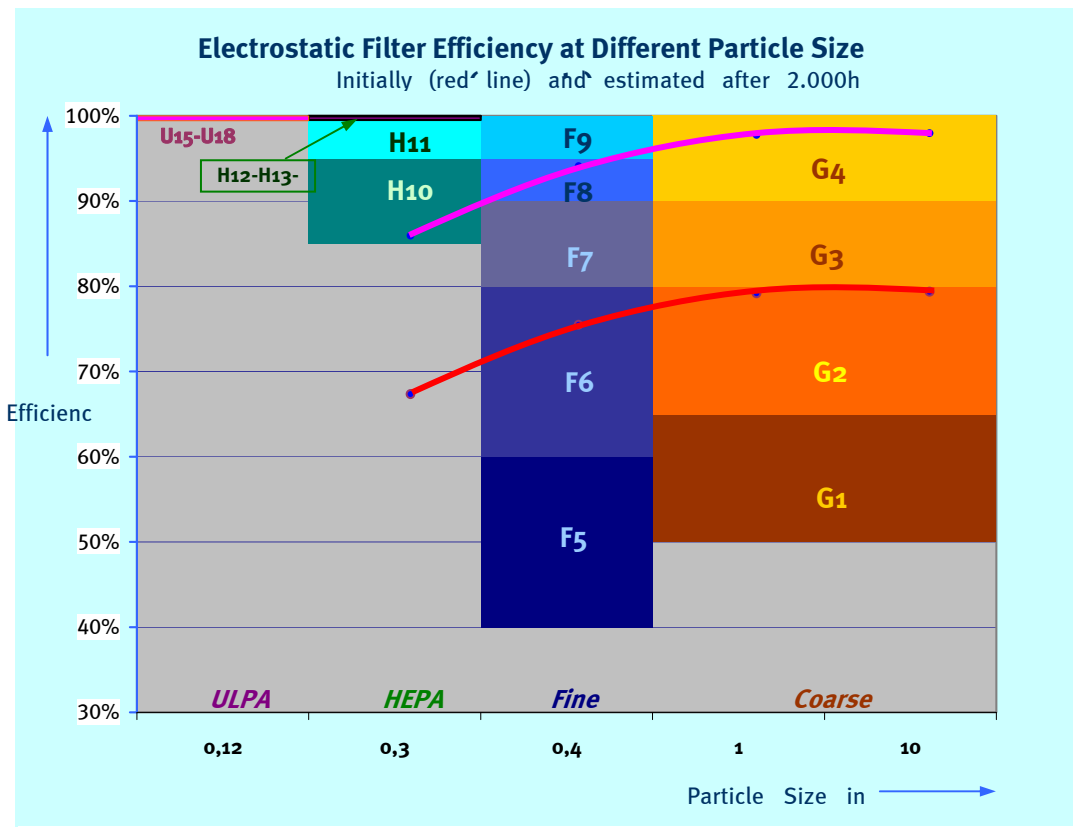
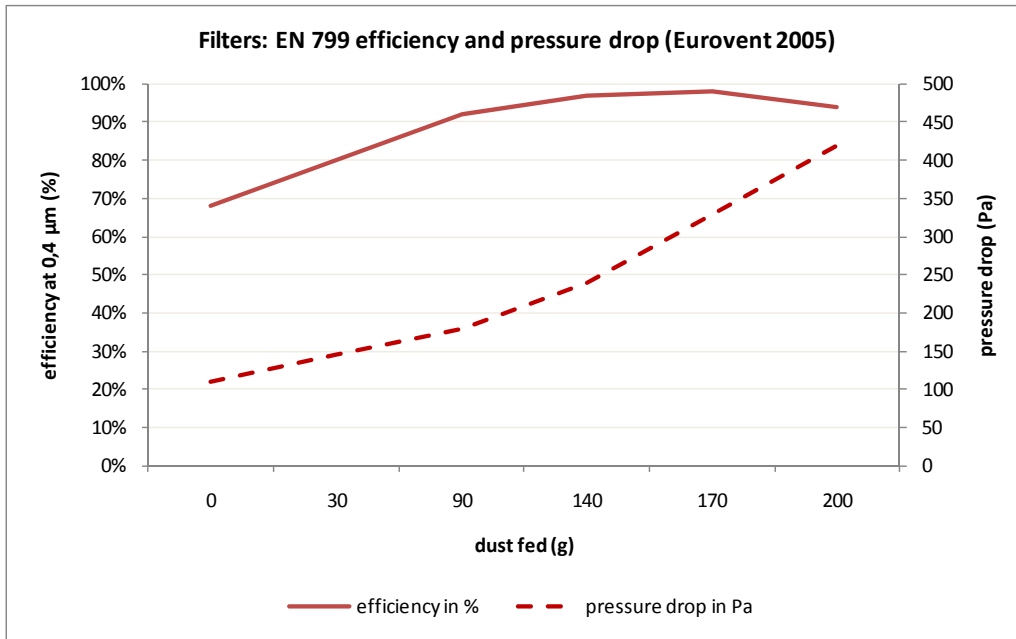

Figure 5-30. Electrostatic filter efficiency at different particle size, initially and after 2.000h. [Source: VHK on basis of industry data 3M]

Following the new EN 779:2002 the manufacturers' association Eurovent has performed round robin tests with nine laboratories, comparing effectiveness of an electrostatic synthetic fibre F7 bag-filter against a mechanical glass fibre F7 bag-filter (10 bags, surface 7,4 m<sup>2</sup>, air flow 3.400 m<sup>3</sup>/h, filtration velocity 0,13 m/s).<sup>28</sup>

In a first test according to EN 779, i.e. with a discharged electrostatic filter, both types showed similar behaviour in terms of efficiency at removing 0,4 µm particles (in %) and the pressure drop (in Pa): a sharp increase in efficiency starting at 70% and stabilizing 95% at around 150 g of dust fed. At the same time the pressure drop increased more slowly from around 125 Pa to 260 Pa at around 150 g of dust fed. Between 150 and 200 g of dust fed the pressure drop increased exponentially from 260 to 420 Pa.

<sup>28</sup> Ginestet, A., Pugnet, D. (CETIAT), Round Robin Test of General Ventilation Filters According to EN 779 Standard, conference paper INDOOR AIR 2005, Beijing (CN).



**Figure 5-31. Mechanical and discharged electrostatic filter (identical) efficiency and pressure drop at increasing amounts of dust absorbed, EN 779 test.** [Source: Ginestet et al. 2005]

In a second 'real-life' test, filters were removed from time to time from their HVAC installation to take the measurements. Filters were ventilated with non-conditioned and non-pre-filtered air. The mechanical filter started at a particle size removal efficiency of 60% and after about 1.250 running hours the efficiency dropped to 50% and stayed there for the rest of the 4.500 h test. The pressure drop, initially ca. 80 Pa, increased only slightly (10-20%) over the duration of the test. The electrostatic filter started at an efficiency of around 75%, which then also dropped to 50% and stayed there for the rest of the test. Also here the pressure drop, initially ca. 110 Pa, increased only slightly (10-20%) over the duration of the test.

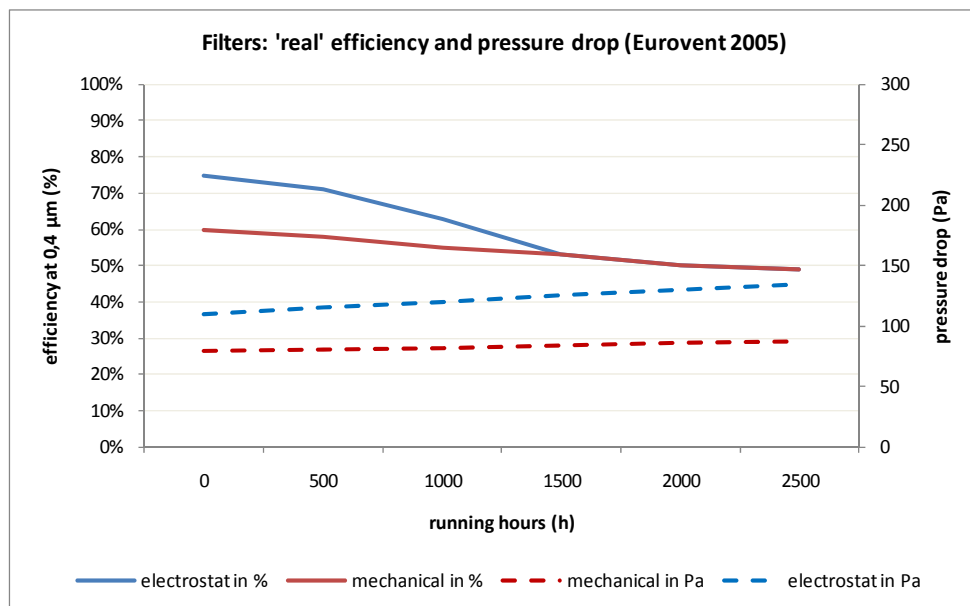

**Figure 5-32. Mechanical and electrostatic filter efficiency and pressure drop as a function of running hours, real-life test.** [Source: Ginestet et al. 2005]

### 3.3.6 Filter bypass leakage and other requirements

The new prEN 13053 (Jan. 2010) stipulates the following requirements regarding filters:

“The task of air filters in HVAC systems is not only to protect the ventilated rooms from too severe a level of contamination but also the HVAC system itself. This is guaranteed by the use of fine filters of filter class F5 to F9 according to EN 779. When manufacturing air filters, no components or materials may be used, this can serve microbes as nutrients.

The requirements for air tightness, strength, and bypass leakage are specified in EN 1886.

The side wall on the service side of the filter section shall be equipped with an inspection door. The width and height of the door shall be greater than the external dimensions of the replaceable filter elements. There shall be a free space to the side of the access door and immediately upstream of front access filters sufficient to allow unrestricted access for filter removal and replacement.

The filter section shall be equipped with tapings for a pressure loss gauge/ manometer.

Additional requirements can be specified which take into account the climatic conditions (e.g. low temperatures, moisture, sand, and salt mist).

NOTE In cold climates the possible accumulation of rime may require the slight preheating of supply air and where there is excessive mist in outdoor air, the moisture running off the filters can necessitate specific requirements for corrosion protection.

#### Filters installed in air handling units

The first filter stage is to be fitted on the intake side, as close as possible to the outer air intake aperture to keep the air treatment elements as clean as possible. Additional coarse filters G1 to G4 are permissible. The second filter stage is arranged on the output side at the beginning of the supply duct in order to keep the ductwork clean.

If a single stage filter system is used for supply air system, a minimum of filter class F7 shall be fitted. If two-stage filtering is used, the supply air fan shall be arranged between the first and second filter stage. To avoid microbial growth on air filters of the second or higher filter stage, the relative humidity in the area of the filter is to be limited to 90 %; dropping below the dew point in the area of the air filter shall always be avoided. Air filters shall not be arranged immediately after coolers with dehumidification or after humidifiers (exception – steam humidifiers).

If bag filters are used, the filter area should be at least 10 m<sup>2</sup> per 1 m<sup>2</sup> equipment cross-section. The seals used shall be of a closed cell type, shall not absorb any moisture and shall not form a nutrient substrate for micro-organisms. A permanent tight fit shall be guaranteed for the seal (e.g. operation from the dusty air side). Starting from an interior height of 1,6 m, the filter chamber should be fitted with an inspection window (sight glass, inside diameter minimum 150 mm) and with light.

For fan selection purposes the filter pressure loss value at design volume flow shall be the average of the initial and final pressure losses for clean and dust loaded filters. The filter section shall be equipped with measuring devices for pressure drop.

NOTE 1 Variation in volume flow caused by the accumulation of dust should be given in technical specifications. If specific tolerances for an application are not specified, ± 10 % based on the average pressure drop is acceptable.

The following data shall be displayed in a clear, visible form (e.g. label) on the filter section: filter class, type of filter medium, final pressure drop. On changing the filter, the user shall check and update this information.”

For residential products, EN 13141-8 gives a classification of filter bypass leakage. Also here EN 1886 is the basis (at 200 Pa). Due to the fact that filter bypass leakage measurements can be difficult to perform, it is also possible to give a classification on the basis of a visual inspection of the design details

**Table 5-11. EN filter bypass leakage classification EN 13141-8 (copy of Task 1, Table 1-8)**

Class	Leakage rate	Proof	Method
FBL 1	< 2%	Measured	EN 1886 (at 200 Pa)
FBL 2	< 4%	Measured	EN 1886 (at 200 Pa)
FBL 3	< 6%	Measured	EN 1886 (at 200 Pa)
FBL 4	Approved	Visual inspection	1. Design & construction of air filter and frames allow easy assembly and tight fit 2. Tight fit shall not be affected under the impact of humidity.
-	Not classified	Not classified	

## 4. Heat Recovery

### 4.1 Introduction and definition

Air-to-air energy recovery devices, also known as ‘heat recovery devices’ or ‘heat recovery systems’ (HRS), are a common component in most new balanced non-domestic ventilation units. They are produced by the ventilation unit manufacturer (i.e. not brought on the market as a separate unit), or they are brought on the B2B market by OEMs as a separate unit or acquired by the installer/end-user as a spare part. In a few countries, like the UK, there are specific incentive schemes to promote energy efficiency of (separate) heat recovery devices.

For instance in the UK they are part of the Energy Technology List in the Enhanced Capital Allowance (ECA) scheme is a key part of the Government’s programme to manage climate change, and is designed to encourage businesses to invest in energy-saving equipment. As such, they are subject to an Energy Technology Criteria List (ETCL), reviewed annually to ensure that it reflects technological progress. It sets out the qualifying energy-saving criteria for each class of technology.

ECA<sup>29</sup> gives the following definition:

Air-to-air energy recovery devices are heat exchanger products that are specifically designed to recover (or salvage) waste heat from the exhaust air stream from a building ventilation system, and use it to heat the incoming air stream to the same building ventilation system.

### 4.2 Categories

The following categories can be distinguished:

1. **Plate heat exchangers (or recuperators).** These products must consist of heat exchanger with alternate channels for the supply and exhaust airflows that are separated by plates through which heat is conducted. They must not contain any moving parts. This category includes both
  - a. cross-flow types, and
  - b. counter-current flow types.
2. **Rotating heat exchangers** (including thermal and desiccant heat wheels). These products must consist of a circular heat transfer medium (or ‘wheel’) that is designed to slowly rotate within an airtight container, and to pass the exhaust air stream over one section of the wheel, and the supply air stream over the other section of the wheel in counter flow direction. The product may be designed to recover only sensible heat, or it may incorporate a desiccant material to enable it to recover both latent and sensible heat.
3. **Run-around coils.** These products must consist of a matched set of two or more air-to-water heat exchangers that are designed to be located in the supply air and exhaust air ducts, and interconnected with a pumped circuit containing water, or water and glycol.
4. **Heat pipe heat exchangers.** These products must consist of an array of tubes containing a working fluid that transfers heat from one end of the tubes to the other by a continuous cycle of evaporation and condensation of the working fluid.

---

<sup>29</sup> ECA ENERGY TECHNOLOGY CRITERIA LIST 2009

EN 308 distinguishes:

- Category I**     Recuperators
- Category II**    With intermediary heat transfer medium
  - \* Category IIa - without phase-change
  - \* Category IIb - with phase-change (heat-pipe...)
- Category III**    Regenerators (containing accumulating mass)
  - \* Category IIIa - non-hygroscopic
  - \* Category IIIb - hygroscopic

The figure below illustrates some of the principles.

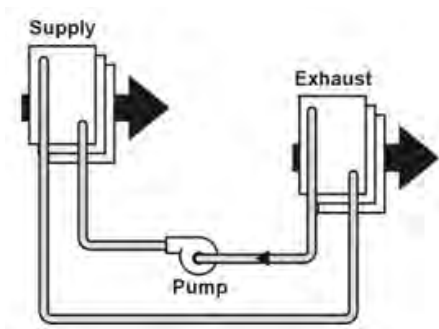
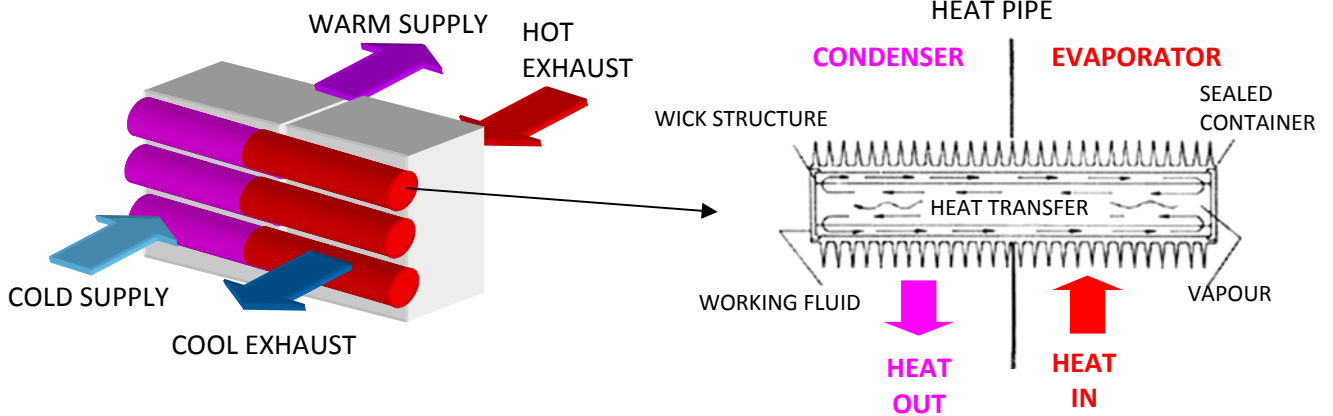
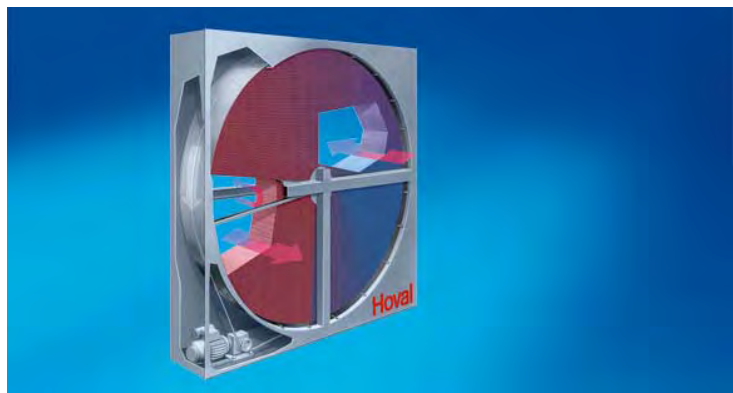

Figure 5-33. Heat Exchangers. Top Left: Cross-flow plate heat exchanger. Top right: rotary wheel. Above: heat pipe heat exchanger. Left: run-around coil

### 4.3 Efficiency

Cross flow heat exchangers are cheap standard products with a relatively low thermal efficiency and a relatively high pressure drop (250-300 Pa). For smaller ventilation units and AHUs they used to be the standard solution until a few years ago.

Counter flow heat exchangers feature high thermal efficiency, with actually claimed efficiencies of 80 to >90%. The pressure drop is linked to the efficiency and air speed, but overall still relatively high (also 250-300 Pa). They are currently used in smaller CHRVs and AHUs. Also in medium sized AHUs they are rapidly becoming more popular as thermal efficiency starts to become more important in the building regulations. Counter flow heat exchangers are most popular e.g. in the Netherlands for 'ventilation only' solutions.

Rotating heat exchangers (a.k.a. 'rotary wheels') are amongst the most efficient heat recovery solution for medium to large-sized AHUs. Efficiencies are in the range of 60 to 85%. Also here the pressure drop is linked to the efficiency and air speed. Typically it ranges from 150 to 300 Pa. Rotary wheels are relatively popular in Scandinavia and Germany.

Run-around coils have a relatively low thermal efficiency (40-70%), but –as compared to cross-flow heat exchangers—they have a smaller pressure drop (50-150 Pa). A main advantage of the run-around coil is that, exhaust and supply duct systems can be separated by a significant distance. This feature reduces the potential for contamination of fresh intake air by exhaust air. In cases where the performance is critical or regulations focus on electricity consumption only, this solution may be used. Run-around-coils are relatively popular in the UK and the US.

Heat pipe heat exchangers are rare. They are expensive, have a relatively low thermal efficiency and a medium-high pressure drop.

Products that meet the requirements in the table below, both for thermal efficiency and pressure drop, are eligible for the Enhanced Capital Allowance in the UK 2010.

**Table 5- 12. ECA minimum effectiveness and pressure drop heat exchangers**

	Product category	Net sensible effectiveness	Pressure drop (in Pascal)
1.	Plate heat exchangers	>= 49%	< 250 Pa across each side.
2.	Rotating heat exchangers	>= 68%	< 200 Pa across each side.
3.	Run-around coils	>= 45%	<100 Pa across each air side and < 25 kPa across each water side.
4.	Heat pipe heat exchangers	>= 49%	<200 Pa across each side.

For Germany, Kaup mentions heat recovery is used in 52% of a large sample (n=13.893) of AHUs sold between 2003 and 2009. He found an average thermal efficiency of 62,4%. Per year of production the thermal efficiency grew substantially. In 2005 it was 58% and in 2009 64,8%. Best Available Technology (occurring at small-medium sizes) was over 85%.

The average pressure loss on the supply side was 168 Pa and on the exhaust side 177 Pa. Average pressure drop increased from 152 Pa in 2005-models to 175 Pa in 2009-models.

## 4.4 Applicable standards

### 4.4.1 Stand-alone devices

Applicable test standards for 'stand-alone' testing of heat recovery devices are

In the EU:

EN 308:1997 "Heat Exchanger: Test procedures for establishing performance of air to air and flue gases heat recovery devices".

In the US (also used in the UK ECA scheme):

ANSI / AHRI 1060:2005 "Performance rating of air-to-air heat exchangers for energy recovery ventilation", Air-conditioning, Heating & Refrigeration Institute.

ANSI/ASHRAE Standard 84-2008 "Method of Testing Air-to-Air Heat/Energy Exchangers" (equivalence to EN 308 is to be proven)

In Japan:

JIS B 8628: 2003, "Air to air heat exchanger".

Task 1 discusses the EU standard EN 308.

### 4.4.2 Integrated in non-residential ventilation units

Applicable standard for performance classification of heat recovery in complete ventilation units for **the non-residential sector** is EN 13503:2006, where a draft is now under review (prEN 13503; Jan. 2010). The energy efficiency  $\eta_e$  is calculated from EN 308 data at reference conditions of +5 °C outside and +25 °C inside. For other-than-reference conditions the values are to be recalculated using thermal efficiency<sup>30</sup>  $\eta_t$  and the coefficient of performance  $\epsilon$ . The equations are

$$\eta_e = \eta_t \cdot (1 - 1 / \epsilon)$$

where the thermal efficiency ( $\eta_t$ ) under dry conditions is

$$\eta_t = (t_2'' - t_2') / (t_1' - t_2')$$

with:

$t_2''$  = temperature of the supply air [°C]

$t_2'$  = temperature of the outside air [°C]

$t_1'$  = temperature of the exhaust air [°C]

and the coefficient of performance ( $\epsilon$ ) is

$$\epsilon = Q_{\text{HRS}} / P_{\text{el}}$$

with maximum heat exchanger capacity  $Q_{\text{HRS}}$  [in kW] :

$$Q_{\text{HRS}} = q_{m2} \cdot c_{pA} \cdot (t_2'' - t_2')$$

where

$q_{m2}$  = smallest of exhaust or supply air mass flow (in kg/s)

$c_{pA}$  = specific thermal capacity [kJ / kg K]

<sup>30</sup> At dry conditions. Annex B of EN 13503 also gives a method to include humidity and latent heat.

with electric power consumption  $P_{el}$  [in kW] is

$$P_{el} = q_v \cdot \Delta p_{HRS} \cdot 1 / \eta_D + P_{el\ aux.}$$

with:

$q_v$  = air flow [m<sup>3</sup>/s] (standard density of 1,2 kg/m<sup>3</sup>)

$\eta_D$  = 0,6 average overall static efficiency of power consumption [./.]<sup>31</sup>

$P_{el\ aux.}$  = auxiliary electric power consumption (e. g. pumps, etc.) in [kW]

$\Delta p_{HRS}$  is the sum of the pressure loss on the supply side and the pressure loss of the exhaust side of the heat recovery system

The table below gives the efficiencies at balance mass flow (1:1), which roughly corresponds with the usual operating conditions.

**Table 5- 13. Heat Recovery energy efficiency EN 13503 classes**

EN 13503 Class	Energy efficiency $\eta_e$ (in %)	$\eta_t$ (in %)	$\Delta p_{HRS}$ in Pa	$\epsilon$
H1	71	75	2 x 280	19,5
H2	64	67	2 x 230	21,2
H3	55	57	2 x 170	24,2
H4	45	47	2 x 125	27,3
H5	36	37	2 x 100	26,9
H6	No requirement	n.a.	n.a.	n.a.

Note that the efficiencies mentioned above apply to thermal efficiency under 'dry conditions'.

EN 13503 further stipulates "requirements for heat exchangers" as follows:

*a) all heat recovery sections should have 4 pressure tapping points, one on each air flow side of the exchanger;*

*b) all heat exchangers shall be fitted with seals to minimise air leakage;*

*c) within heat recovery sections fitted with category I and II heat exchangers there shall be a drain pan for condensate;*

*d) category III heat exchangers shall include a purge sector, except when recirculation air is used.*

In comparison: EN 13779 mentions that for a 'H3' heat recovery device a pressure drop of 150 Pa is 'normal' (low 100 Pa, high 250 Pa). For 'H1' and 'H2' devices a pressure drop of 300 Pa is 'normal' (low 200 Pa, high 400 Pa).

Kaup mentions that currently (2009) the average HR energy efficiency is almost in class H2 and therefore H2 might be a feasible long term (2-3 years?) target.

<sup>31</sup> Note that in EU-27 an average efficiency of 0,4 is used for power generation and –distribution.

#### 4.4.3 Integrated in residential ventilation units

In the **residential sector** standards like EN 13142-7/ -8 (i.e. also the collective residential sector, which is in the scope of the study) the heat recovery is not given as energy efficiency (i.e. including the effect of the electricity consumption) but as 'temperature ratio', measured at reference air volume and –pressure and at a nominal temperature difference  $\Delta T=13$  K.

The resulting classification (1=best; 6=worst) has lowest class limits of 90% (class 1), 80% (class 2), 70% (class 3), 60% (class 4), 50% (class 5) and <50% (class 6).

A related parameter is the Nominal Temperature Performance Factor in EN 13142 (see Task 1 report).

## 5. Controls

### 5.1 Introduction

'Controls' comprises all products and components that regulate the ventilation unit performance. A distinction can be made between

- 'open loop' controls such as manual switches/dials and clock timers directly regulating fan operation/speed, and
- 'closed loop' controls where fan operation and speed is regulated through a loop between sensor(s), central processing unit (CPU) and actuator(s).

This chapter will focus only on Indoor Air Quality controls. Auxiliary controls, e.g. thermostats for defrost preheating, timers or pressure switches indicating filter replacement, etc., are considered standard technology and not –however useful—discussed in detail.

In the Task 3 report, already a number of actuators such as motorized dampers (also sometimes called VAV-boxes, but of a type much simpler than with air conditioning systems) were introduced. Also in this Task 5 report, under Fan Systems (Chapter 2), the principle of SPR (Static Pressure point Reset) and constant-pressure systems was discussed.

Although, in fact, SPR represents the state of the art in VAV box control, it means that this chapter can now concentrate on trends and highlights in BAT and BNAT. Also the quantification of the control fact (CTRL) that was introduced in the Task 4 report will be discussed.

Sensor technology

EN 13799 gives the following classification of control types, mainly characterized by the controller or sensor type.

**Table 5-14. EN 13799, Possible types of control of the indoor air quality (IDA-C)**

Category	Description
IDA – C 1	No control The system runs constantly.
IDA – C 2	Manual control The system runs according to a manually controlled switch.
IDA – C 3	Time control The system runs according to a given time schedule.
IDA – C4	Occupancy control The system runs dependent on the presence (light switch, infrared sensors etc.)
IDA – C5	Demand control (number of people) The system runs dependent on the number of people in the space.
IDA – C 6	Demand control (gas sensors) The system is controlled by sensors measuring indoor air parameters or adapted criteria, which shall be specified (e.g. CO <sub>2</sub> , mixed gas or VOC sensors). The used parameters shall be adapted to the kind of activity in the space.

According to the standard, demand control through gas sensors (class IDA-C6) constitutes the Best Available Technology. On this there is little dispute in the sector.

There is, especially in France, some question whether a Relative Humidity sensor should be counted as a 'gas sensor' and thus qualify as IDA-C6.

In practice this is not really a question: Most manufacturers in the IDA-C6 class would also take a (relatively cheap) RH sensor on board, besides the CO<sub>2</sub>, mixed gas or VOC sensor. Control of the overall air quality on the basis of an RH sensor alone does not occur (and would not work) in a non-residential building.

In multi-family residential buildings, especially with exhaust systems for the wet rooms, a control on the basis of RH sensors alone is more common. In that case it works as IDA-C5 type, i.e. indicating the total number of people that are taking a shower at any given time. Outside the hours when the bathroom or kitchen is used the ventilation system would then fall-back to a mid-position.

In the class IDA-C6, only a CO<sub>2</sub>-, mixed gas or VOC sensor can determine not only the occupancy of a room, but also the occupancy rate and activity level. Of these types, the CO<sub>2</sub> sensor is the most popular, because it does the job and over the past few decades the prices have dropped dramatically. In the 1990's production costs for a CO<sub>2</sub> sensor were as high as € 2.000 to € 3.000. At the moment, the FGK report on domestic ventilation estimates the OEM price at not higher than € 50,- and a realistic –without commercial bonus-- customer end price (incl. VAT) at € 170,- (see Task 2 export, Annex V).

Currently, most manufacturers of balanced ventilation units have CO<sub>2</sub>-sensor controls in their catalogue, either as an accessory or part of a package or both. For exhaust systems it is less common, but has started in the last 2 to 3 years especially for individual dwellings and small commercial applications.

TVOC (Total Volatile Organic Compounds) and mixed gas sensors started out as a ventilation control in ambients where exhaust fumes and fuel vapours were ubiquitous, like truck cabins, buses, etc.. In ventilation control for non-residential buildings they are less well-known, although e.g. in the catalogue of AL-KO they are presented as the "better alternative" to CO<sub>2</sub> sensors, under the name of AirQualitizer. This device features the "LuQAS Triple Sensor" which is able to detect oxidizing organic compounds through an array of gas sensors. In that sense, it is "better" than a CO<sub>2</sub>-sensor in the sense that it actually measures harmful pollutants also from non-human sources such as the building fabric, textiles, appliances (e.g. certain printers), tobacco smoke, etc.. In contrast, the CO<sub>2</sub> sensor is mainly used to detect human occupancy and activity level, as an indicator of the level of pollution by the largest polluter; CO<sub>2</sub> in itself –unless present in very high doses—is relatively less harmful. The first LuQAS sensor was developed by ETR GmbH around a decade ago, and further researched with aid of the German government by UTEC, Bremer Energie Institut, Bremer Umwelt Institut<sup>32</sup>. The original aim was the use in automatic ventilation control to save energy, but was then tested more as an educational tool. The research could not conclude to a clear energy saving effect.

The diagram below shows measurements of the LUQAS sensor, a separate VOC sensor and a CO<sub>2</sub> sensor. Note that the right hand scale is tuned to TOC measurements; for CO<sub>2</sub>, which usually moves in the range of 1.000 to 2.000 ppm and control intervals of less than 100 ppm, it is too rough.

---

<sup>32</sup> Kopske et. al., Wissenschaftliche Begleitung sowie Verifizierung des Einsatzes einer Luftampel im Mietwohnungsbau und Schulen, UTEC/ Bremer Energie Institut/ Bremer Umwelt Institut, Bremen, August 2004.

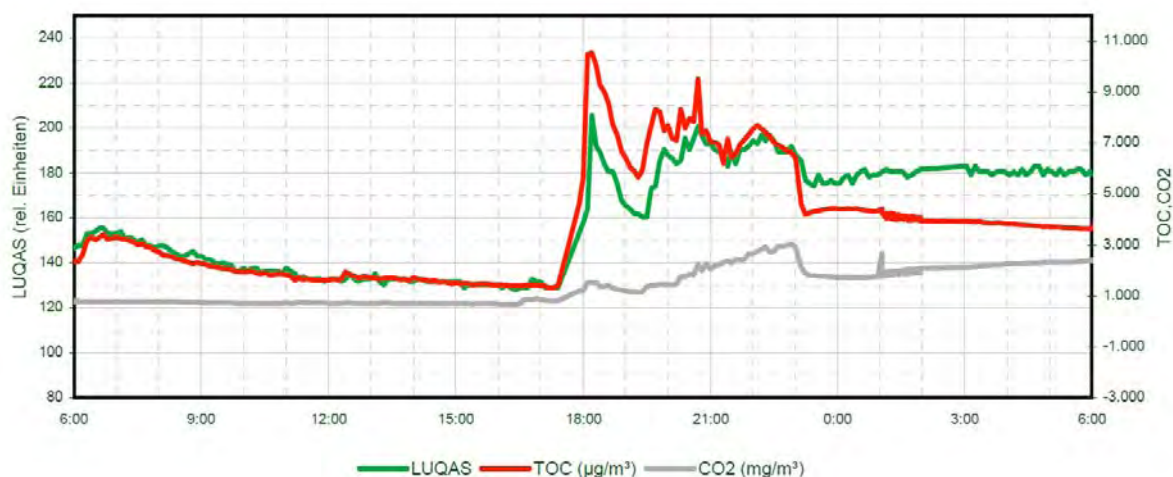

**Figure 5-34. Parallel measurement of LUQAS, TOC and CO<sub>2</sub> sensors in a (non-ventilated) living room.**

VHK concludes from this graph that, with an upgraded CO<sub>2</sub>-scale scale, the sensor read-outs are similar. The main difference between the LUQAS read-out and the CO<sub>2</sub> read out is that the former has a quicker response time (around 20 minute's difference, from literature) and a lower inertia. Whether this is an advantage from the point of view of energy saving is questionable, because also ducted air ventilation systems have their own inertia to take into account.

From the above VHK concludes that—at least in terms of energy efficiency—VOC, mixed gas and CO<sub>2</sub> sensors are equivalent and all constitute the best available technology (BAT). For all of these sensors, a relative humidity and temperature sensor has to be added to correct for drifts ('re-calibration').

## 5.2 Controls for central exhaust ventilation units (CEXH)

Apart from improvements in the fan efficiency, 'controls' constitute the main energy saving opportunity for exhaust systems (System C, mechanical exhaust, natural air supply). At the moment, exhaust systems are a low-cost solution for non-residential buildings and multi-family residential dwellings. And the present status of controls mostly reflects this low-initial-cost priority of the buyer. Currently most exhaust ventilation units are: a) running at constant speed all year around 24/7 or b) running with a simple night-setback regime 8-10 hours per day at reduced (50%) speed. The fans are driven by:

simple single speed AC motors (CTRL=1,33),

2 or 3 speed AC motors, fixed to the appropriate speed at installation (CTRL=1) or

2 or 3 speed AC motors or—increasingly—more efficient VSD EC motors where speed can be controlled manually (CTRL=0,9, CTRLV=0,9) or by a clock timer (CTRL=0,75, CTRLV=0,75)

In the latter case, the controller can either be 'wired' or 'wireless' (radiographic) for easy accessibility by the user.

Demand-control, where the exhaust fan is operated by relative humidity (RH) sensors (for wet rooms, most common in multi-family buildings), optical occupancy sensors and/or CO<sub>2</sub> sensors, is rare. But if it happens, the RH or CO<sub>2</sub> sensors are usually placed at central level, i.e. near the fan. A surge in relative humidity or CO<sub>2</sub> would then trigger the central fan to switch from mid to top-speed. A low in humidity or CO<sub>2</sub> would bring it in the low-position. The utility of such a sensor control (CTRL=0,7) is barely higher than that of a smartly set clock-timer.

Considerably more saving, and probably qualifying as BAT for exhaust systems at CTRL=0,5, is given with local sensors and local actuators, with at least the actuator position and/or a local measurement of the static pressure communicated to the CPU. As an example, the Plenum Box solution is presented which could be used in small non-residential applications and offered as a single package or as separate accessories. The box is in fact a 'divider' of the exhaust air extracted from up to 8 different rooms. The box contains 8 valves operated individually by an external CPU, a humidity sensor and a CO<sub>2</sub>-sensor. The sensor consecutively samples the RH (for wet rooms) or CO<sub>2</sub> level of the air from each individual room. The CPU then controls the individual valve positions and overall fan speed. See figure below:

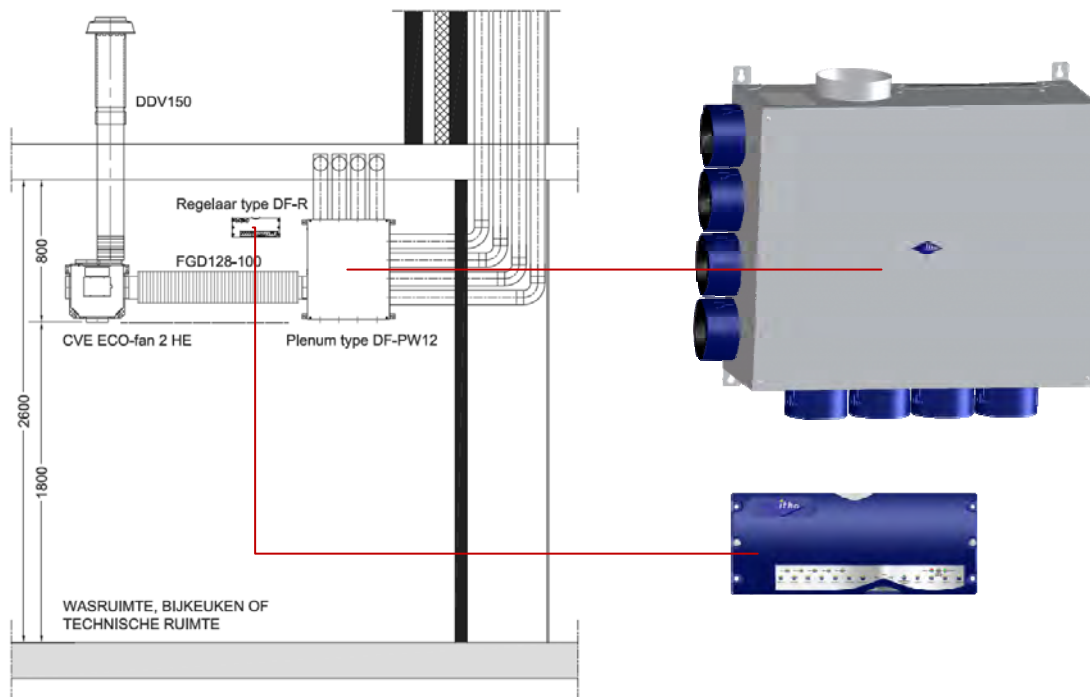

**Figure 5-35. Plenum Box with controller, market introduction Sept. 2009** [source: Itho]

With respect of a standard exhaust system (CTRL=1) this solution saves 50% in air flow, i.e. space heating energy to heat the cold air (CTRL=0,5), and around 80% ( $CTRLV=1-0,5^3=0,8$ ) in electricity consumption. Furthermore, the fan is high efficiency DC fan (efficiency at level IE4), saving yet another 5% on electricity consumption.

Overall, instead of consuming 1000 kWh/year for the CEXH Base Case, the solution is consuming only 200 kWh/year in electricity. The space heating saving of the CEXH Base Case is doubled.

The above example was chosen because fan, controller and plenum box are put on the market as a single package and could as such be rated. More common, and already possible for a few years, is the situation where a system designer puts together such a locally controlled exhaust system from individual components of several suppliers. In that case the rating can only take place a posteriori.

The BNAT solution for this control system should probably tackle at least one flaw of this system, i.e. reduce the pressure loss that is inherent from the suboptimal position of the VAV valves (i.e. close to the box and fan) and the relatively narrow (80 mm diameter) ducts. In that way a few extra percent of saving may be squeezed from this solution and savings might be up to 85%.

### 5.3 Controls for central heat recovery ventilation units (CHRV)

CHRV units are either upgraded individual dwelling units or down-sized air handling units (AHUs) and differentiated from the latter by the fact that they are not equipped to fold a heating or cooling coil. They are made to realize energy saving and comfort and still relatively easy installation, at least of the units themselves and also their controls.

They are standard equipped with at least manual controllers (CTRL=0,9) and often timer solutions (CTRL=0,8).

Single speed AC fans are not used and most are equipped with high efficiency EC motors and variable speed drives and –due to relatively low face velocities—effective heat recovery.

This marks their biggest difference with exhaust systems in terms of control solutions: they are already much more efficient to start with and can boost a higher saving in space heating energy (with respect of natural ventilation) through heat recovery. And of course, because they have both an exhaust and supply side, the investment costs will be higher.

As a result the saving potential of local demand control is lower and the investment costs are almost twice as high. Having said that, the savings through local demand (CO<sub>2</sub> and RV) control will still be in the range of around 30%. An example of a package with local CO<sub>2</sub> sensors (but without local actuators) is given in the Annex IV of the Task 2 report.

Extra saving on cooling (see Air conditioning systems, Task 5 report) can be achieved by free night-cooling. This requires a bypass around the heat recovery unit to diminish the system pressure loss, increase the effective flow rate and keep the filters and heat exchanger clean. In the latest generation of CHRV units this is usually a standard feature.

### 5.4 Controls for air handling units (AHUs)

Air handling units are usually (95%) combining ventilation with cooling/heating and it is customary that the ventilation controls are NOT delivered as part of a self-standing package and therefore the rating of Building Control Systems, VAV-boxes with DDC (Direct Digital Control) and a whole myriad of communication ('BUS') controls is NOT in the scope of the study.

From a practical point of view we can only judge whether an AHU is prepared for the best control, e.g. with a good variable speed control (Variable Speed Drive/ Variable Frequency Drive), to accommodate all the appropriate sophisticated system solutions. This means that we must assume that the optimal solution will be applied, i.e. an SPR-control with local sensors and appropriate VAV-boxes. If such an optimal solution is enforced through legislation, must be regulated through the EPBD or national building codes.

## 6. Summary BAT and BNAT

### 6.1 BAT

Strict unit items:

- Backward-curved 'air foil' centrifugal fans;
- Variable speed drives (<10 kW: DC motor with controller; >10 kW fan motor: 3-phase AC motor with VFD);
- Direct transmission (no belt drive);
- Brushless DC (BLDC) motors >95% efficiency for fans up to 10 kW, 'IE3' level AC for > 10 kW (also ca. 95% at 100 kW) ;
- Pre-dominantly low speed (25-30% of design air flow) fan operation;
- Low face velocity (ranging from <0,5 m/s for small units till <1,5 m/s for largest AHUs), through large filter sections, large heat recovery faces, large and aerodynamically optimal fan- and outlets;
- Minimal short-circuiting and low leakage rates and, i.e. fan casing leakage, heat recovery unit cross-over leakage, filter bypass leakage
- Electrostatic EU7 filters (or higher) on supply side (resistance <60 Pa initial, <100 at end-of-life);
- More frequent filter change (1.250 h), signaled through  $\Delta p$  sensor (larger units) or timer (smaller units);
- High-efficiency heat recovery;

System items (may or may not be part of measures/ rating):

- Local sensor control for air-flow, possibly supplemented by timer or occupancy control for on/off;
- Gas sensor-control of air-flow (IDA-C6), supplemented by RH and temperature sensors for calibration or (with RH sensor) occasional excessive humidity;
- Low resistance actuators (VAV-boxes, demand-flow ATDs, etc.);
- Air-side distribution control through SPR (Static Pressure Reset);
- Low resistance and low leakage ductwork (large face section, low leakage rate, minimal bends and reductions, appropriate aerodynamics and friction losses, smooth wall surface, optimised design for the most frequent critical path(s), etc.);
- Flue gas pre-heat of supply air (extra heat exchanger or supplement to existing HRS).

It is estimated that through the strict unit-related items, an energy saving of >60% is possible with respect of the Base Case, even with current practice as regards systems.

Including the system items, an energy saving >80% with respect of the Base Cases is possible.

## 6.2 BNAT

After the realization of the BAT, principally an evolutionary development is envisaged, which may lead to yet another 5-10%. For instance, it is to be expected that brushless DC motors will be used in fan applications up to 100 kW (currently only used in electric cars).

In parallel also the thinking about mechanical ventilation may change, away from the large centralized systems and more towards downsized, local or zonal solutions. Key features may be:

- Increase number of ventilation units per building system;
- Downsize single ventilation system, smart balance between large and small units;
- Increase fan impeller diameter;
- Structurally decrease fan speed, at nominal design air flow;
- Minimal ductwork, optimal use of atriums, staircases, halls, double façade, full air-tight building shell, remaining ductwork with very large face sections;
- 'hybrid' solutions, probably also more slow-moving axial fans;
- Renovation: through the wall solutions, integration with façade renewal;
- Local VSD ventilation solutions to replace local VAV-box;
- Low speed it can be expected that the current trends will continue: Ventilation and air conditioning (space cooling and/or heating) will be more and more separate systems.

## 7. List of Tables

Table 5- 1. Key data AL-KO sample .....	14
Table 5- 2 .Examples for efficiency for specific components in central air system .....	20
Table 5- 3. Ecodesign Fan Regulation 2010, summary and examples .....	25
Table 5- 4: Comparison of features of main motor types used for fans.....	26
Table 5- 5: Rule-of-thumb component pressure drops for large buildings .....	31
Table 5- 6: Example of aggregating component pressure drops though a ventilation system in a large building, at design flow rate. ....	32
Table 5- 7. Examples for pressure drops for specific components in air handling systems .....	32
Table 5- 8. Air Filter Classes .....	40
Table 5- 9. Examples for pressure drops for specific components in air handling systems .....	41
Table 5- 10 . Maximum final pressure drop for filters (EN 13503. Table 9) .....	41
Table 5- 11. EN filter bypass leakage classification EN 13141-8 .....	45
Table 5- 12. ECA minimum effectiveness and pressure drop heat exchangers.....	48
Table 5- 13. Heat Recovery energy efficiency EN 13503 classes .....	50
Table 5- 14. EN 13799, Possible types of control of the indoor air quality (IDA-C).....	52

## 8. List of figures

Figure 5- 1: Losses from a traditional belt-driven centrifugal fan .....	6
Figure 5- 2: Plenum (plug) mounted centrifugal fans with direct drive .....	7
Figure 5- 3: F-wheel, B-wheel and T-wheel centrifugal fans in scroll housing .....	7
Figure 5- 4: Typical fan curve for B-wheel fan, showing total & static pressure rise, and total & static efficiency.....	8
Figure 5- 5: (a) Axial fan in a wall panel, (b) efficient axial fan with variable-pitch swept blades.....	9
Figure 5- 6: Typical fan curve for axial fan, showing total & static pressure rise, and total & static efficiency.....	9
Figure 5- 7: Mixed flow fan with variable pitch impellers .....	9
Figure 5- 8: Two examples of centrifugal fans for intermittently fan-assisted stack ventilation. ....	10
Figure 5- 9: Example of axial fan for continuous fan-assisted residential stack ventilation. ....	10
Figure 5- 10: Fan peak efficiency curves.....	11
Figure 5- 11: Best efficiency point (bep) for a single speed fan system. ....	12
Figure 5- 12: Fan curve illustrating optimum region for supply fan selection. ....	13
Figure 5- 13: Fan curves. ....	13
Figure 5- 14: Fan curves two alternative fan sizes, showing the location of surge regions that should be avoided during part-load operation. ....	14
Figure 5- 15. Costs and savings of lowering face velocity (source: AL-KO).....	15
Figure 5- 16. 3D curve of pressure (DP), air flow (CFM) and efficiency (EFF) for a 49" housed airfoil fan (Hydeman et al.) .....	16
Figure 5- 17. Max speed curve (green) plus curves for pressure difference (blue) and absorbed power (brown) when diminishing fan speed/air flow starting from the design operating point. ....	17
Figure 5- 18: Illustration of constant static pressure control. ....	18
Figure 5- 19: Illustration of SPR control. ....	19
Figure 5- 21. Statistical distribution of fan system efficiency supply air .....	21
Figure 5- 1. Statistical distribution of fan efficiency supply air.....	21
Figure 5- 22: Peak motor efficiency depending on motor size, for different motor types. ....	27
Figure 5- 23: Part-load efficiency curves of 3-phase AC motors.....	28
Figure 5- 24: Approximate part-load efficiency curves of the combination of direct-drive AC fan motor and VFD, depending on size (kW).....	28
Figure 5- 25: Example of poor design that generates spin in the same direction as fan rotation. ....	34
Figure 5- 26: Velocity profile at outlets of centrifugal and axial fans.....	35

Figure 5- 27: Example of a fan outlet with a reduction giving a satisfactory transition angle (<30°), and a bend that follows the air spin and the eccentric reduction. .... 35

Figure 5- 28: Impact of the efficiency of different outlets from centrifugal fans. .... 36

Figure 5- 29. Filter types and pressure drop, in Pa vs. fan velocity in m/s. .... 39

Figure 5- 30. Electrostatic filter efficiency at different particle size, initially and after 2.000h. .... 42

Figure 5- 31. Mechanical and discharged electrostatic filter (identical) efficiency and pressure drop at increasing amounts of dust absorbed, EN 779 test. .... 43

Figure 5- 32. Mechanical and electrostatic filter efficiency and pressure drop as a function of running hours, real-life test. .... 43

Figure 5- 33. Heat Exchangers. Top Left: Cross-flow plate heat exchanger. Top right: rotary wheel. Above: heat pipe heat exchanger. Left: run-around coil..... 47

Figure 5- 34. Parallel measurement of LUQAS, TOC and CO2 sensors in a (non-ventilated) living room. .... 54

Figure 5- 35. Plenum Box with controller, market introduction Sept. 2009 ..... 55

## 9. References

Ragden, Peter. Market Study for Improving Energy Efficiency for Fans. Stuttgart: Fraunhofer-Informationszentrum Raum and Bau (IRB) Verlag. ISBN 9783816761372

Schild, P.G. 'Ductless ventilation - Refurbishing an old listed building into modern energy-efficient offices'. In Indoor Air 2008, proceedings. 2008, paper ID 646.

Overview of reports from the EU-RESHYVENT project on residential hybrid ventilation. [www.aivc.org](http://www.aivc.org)

Hydeman, Taylor, Stein, Kolderup & Tong. 'Advanced Variable Air Volume System Design Guide', CEC Report P500-03-082-A-11, October 2003.

de Almeida, A.T.; P. Angers; C.U. Brunner; M. Doppelbauer. Motors with Adjustable Speed Drives: Testing Protocol and Efficiency Standard. 2009

K. Mehlsen, Eleffektiv dimensionering af ventilationsanlaeg (Electricity-efficient design of air-handling systems), Report to the Danish National Board of Buildings, by Crone and Koch, Rådgivende Ingeniørfirma A/S, Charlottenlund, Denmark, 1989 (in Danish).

Wachsfeldt, B.J. & P.O. Tjelflaa. 'Field Measurements of Pressure Characteristics for Components in a Hybrid Ventilation System'. Int. J. Ventilation. Vol.3 (2005), No.4, pp.295-306

Riviere, P. et al. 'Preparatory study on the environmental performance of residential room conditioning appliances (airco and ventilation) — Study on residential ventilation - Final report', November, 2008. Contract TREN/D1/40-2005/LOT10/S07.56606

Weale; Rumsey; Sartor & Lock. 'Laboratories for the 21st Century: Best Practices. Low-pressure drop HVAC design for laboratories'. US-DoE, doc. DOE/GO-102005-2042. Feb. 2005